

2 0 1 3

M I C H I G A N

# HUNTING AND TRAPPING DIGEST

— Rules apply from August 1, 2013 through July 31, 2014 —

## MAJOR CHANGES

- Youth and 100 Percent Disabled Veteran Hunt has been renamed “Liberty Hunt,” see pgs. 26 and 30
- Special 100 Percent Disabled Firearm Hunt has been renamed “Independence Hunt,” see pg. 30
- New Antler Point Restrictions see pg. 32



RAP (Report All Poaching): 800-292-7800

visit us online at [michigan.gov/dnr](http://michigan.gov/dnr)



# MICHIGAN HUNTING AND TRAPPING DIGEST

## - CONTENTS -



The Michigan Department of Natural Resources is committed to the conservation, protection, management, use and enjoyment of the State's natural and cultural resources for current and future generations.

...

The Michigan Natural Resources Commission (NRC) is a seven-member public body whose members are appointed by the governor and subject to the advice and consent of the Senate. The commission conducts monthly, public meetings in locations throughout Michigan. Citizens are encouraged to become actively involved in these public forums. For more information visit [michigan.gov/nrc](http://michigan.gov/nrc).

...

- License Types and Fees** ..... 4
- Season Dates and Bag Limits** ..... 8
- When and Where to Hunt** .....11
- Equipment Regulations** .....17
- Youth Hunting** .....25
- Hunters with Disabilities** .....28
- Deer** .....31
- Small Game and Upland Game Birds** .....39
- Waterfowl** .....41
- Fur Harvesting** .....44
- Wildlife Diseases** .....56
- General Information** .....58

**NOTICE:** This brochure is not a legal notice or a complete collection of hunting regulations and laws. It is a condensed digest issued for hunters convenience. Copies of Wildlife Conservation Orders, which contain complete listings of regulations and legal descriptions, are available on our website: [www.michigan.gov/dnr/laws](http://www.michigan.gov/dnr/laws)

The Michigan Department of Natural Resources provides equal opportunities for employment and access to Michigan's natural resources. Both state and federal laws prohibit discrimination on the basis of race, color, national origin, religion, disability, age, sex, height, weight or marital status under the Civil Rights Acts of 1964 as amended (MI PA 453 and MI PA 220, Title V of the Rehabilitation Act of 1973 as amended, and the Americans with Disabilities Act). If you believe that you have been discriminated against in any program, activity, or facility, or if you desire additional information, please write: Human Resources, Michigan Department of Natural Resources, P.O. Box 30028, Lansing, MI 48909-7528 or the Michigan Department of Civil Rights, Cadillac Place, Suite 3-600, 3054 W. Grand Blvd., Detroit, MI 48202 or the Division of Federal Assistance, U.S. Fish and Wildlife Service, 4401 North Fairfax Drive, Mail Stop MBSP-4020, Arlington, VA 22203.

This publication is available in alternative formats upon request.

The State of Michigan allows appropriate advertising in it's annual hunting and trapping digest to reduce the cost of printing. Many states have adopted a similar strategy. Promotional advertising does not constitute endorsement by the Michigan Department of Natural Resources.



Stay on top of the latest news from the Michigan DNR!  
Visit us at [michigan.gov/dnr](http://michigan.gov/dnr) and click on the red envelope to sign up for e-mail updates!

# the hunt is on... gear up

great brands. great prices. go.



### Limited-License Hunts

Applications for limited-license hunts (bear, elk, antlerless deer, turkey and waterfowl) may be purchased during the designated application period from license agents or online at [www.michigan.gov/huntdrawings](http://www.michigan.gov/huntdrawings).

Limited-License Hunt	Application Period	Approximate Availability of Species-Specific Hunting Digests	
<b>Pure Michigan Hunt</b>	Mar. 1 - Dec. 31		
<b>Spring Wild Turkey</b>	Jan. 1 - Feb. 1		End of Dec.
<b>Bear</b>	May 1 - Jun. 1	For license and season information, see species-specific hunting digests for these hunts, which are published separately from this digest. <b>View digests at:</b> <a href="http://www.michigan.gov/dnrdigests">www.michigan.gov/dnrdigests</a>	End of April
<b>Elk</b>	May 1 - Jun. 1		End of April
<b>Fall Wild Turkey</b>	Jul. 1 - Aug. 1		End of June
<b>Antlerless Deer</b>	Jul. 15 - Aug. 15		Beginning of July
<b>Reserved Waterfowl</b>	Aug. 1-28		End of July
<b>Waterfowl</b>	No applications		End of August
<b>Wolf</b>	No applications		End of July

### To Purchase a License

You must have one of the following forms of identification:

- Valid **Michigan driver's license**
- State of **Michigan ID card** (issued by the Secretary of State)
- **DNR Sportcard** (issued through license agents or at [www.mdnr-eligence.com](http://www.mdnr-eligence.com)). If the information on your DNR Sportcard from a previous year is still accurate, you should continue to use it.

**All hunters born after January 1, 1960** must also present their hunter safety certificate or previous hunting license or sign their license in the presence of the license agent. Your signature certifies that you meet the residency and hunter safety requirements to purchase the license. This also applies to hunters who intend to hunt furbearers under a fur harvester license.

- All **licenses must be signed** to be valid.
- **When hunting or trapping, you must carry your license and the identification used to purchase that license.**
- It is illegal to use another person's hunting license.
- A junior fur harvester-trap only license is available for youngsters who do not satisfy the firearm training requirements for purchasing a hunting license.

**continued on pg. 6 - qualifications for fur harvester licenses**

You can purchase your hunting and trapping licenses online at: [michigan.gov/dnr](http://michigan.gov/dnr)

Item #	License Type	Cost
000	DNR Sportcard	\$1.00
320	Mentored Youth (9 and younger <sup>2,3</sup> )	\$7.50
<b>Small Game - Valid through Mar. 31, 2014</b>		
130	Small Game (age 17 or older)	\$15.00
132	Junior Small Game (age 10-16 <sup>2</sup> )	\$1.00
131	Senior Small Game (65 or older)	\$6.00
133	Nonresident Small Game (age 17 <sup>1</sup> or older)	\$69.00
134	3-Day Nonresident Small Game (age 17 <sup>1</sup> or older)	\$30.00
<b>Gamebird Hunting Preserve - Valid through Mar. 31, 2014</b>		
139	Gamebird Hunting Preserve (age 10 or older)	\$15.00
<b>Fur Harvester - Valid through Mar. 31, 2014</b>		
190	Fur Harvester (age 17 or older)	\$15.00
192	Junior Fur Harvester (age 10-16 <sup>2</sup> )	\$7.50
195	Junior Fur Harvester TRAP ONLY (age 16 and younger <sup>2,3</sup> )	\$7.50
194	RES Fur TRAP ONLY (age 17 or older)	\$15.00
191	Senior Fur Harvester (65 or older)	\$6.00
117	Nonresident Fur Harvester (age 17 <sup>1</sup> or older)	\$150.00
<b>Deer - licenses expire at end of season for which they're issued</b>		
140	Firearm Deer (age 17 or older)	\$15.00
141	Junior Firearm Deer (age 10-16 <sup>2</sup> )	\$7.50
143	Senior Firearm Deer (65 or older)	\$6.00
142	Nonresident Firearm Deer (age 17 <sup>1</sup> or older)	\$138.00
145	Archery Deer (age 17 or older)	\$15.00
147	Junior Archery Deer (age 10-16 <sup>2</sup> )	\$7.50
146	Senior Archery Deer (65 or older)	\$6.00
148	Nonresident Archery Deer (age 17 <sup>1</sup> or older)	\$138.00
340	Combination Deer (age 17 or older)	\$30.00
342	Junior Combination Deer (age 10-16 <sup>2</sup> )	\$15.00
341	Senior Combination Deer (65 or older)	\$12.00
343	Nonresident Combination Deer (age 17 <sup>1</sup> or older)	\$276.00

<sup>1</sup> Nonresidents under age 17 may purchase resident licenses.

<sup>2</sup> For complete information on Youth Hunting, see pgs. 25-27.

<sup>3</sup> Must be age 8 or older to obtain kill tags for bobcat, otter, marten or fisher.

#### Sportsperson Discount

A 15-percent discount is provided when four or more licenses are purchased at one time for the same person. The 24-hour fishing license, all-species upgrade, waterfowl hunting license and restricted hunting applications are not eligible for this discount.

#### Lost Licenses

You may purchase a replacement license at any license dealer. You must provide the identification number used to purchase the original license. The full price will be charged to replace any license with a kill tag. All other licenses will cost \$3.00.

- If you lose a private-land antlerless deer license, contact a DNR Customer Service Center on back of digest.
- For a replacement Michigan hunter safety certificate go to [www.michigan.gov/recreationsafety](http://www.michigan.gov/recreationsafety).

continued

**To qualify for any adult resident hunting or fur harvester license, you must meet one of the following criteria:**

- Reside in a settled or permanent home or domicile within the boundaries of this state with the intention of remaining in this state. The ownership of land in Michigan by itself is not a qualification for a resident license.
- Be a full-time student at a Michigan college or university.
- Serve full-time in the U.S. military and be officially stationed in Michigan.
- Serve full-time in the U.S. military and maintain residency in Michigan.

## Apprentice Hunting License

A person who does not have a hunter safety certificate and is 10 years of age or older may purchase an apprentice hunting license. An apprentice hunter may purchase this license for two license years before he or she must successfully complete a hunter safety course. The apprentice hunting license is available to residents and nonresidents. When afield, an apprentice hunter must be accompanied by someone 21 years old or older who possesses a regular current-year hunting license for the same game as the apprentice. For apprentices between ages 10-16, the accompanying hunter must be the apprentice's parent, guardian or someone designated by the parent or guardian. "Accompanied by" requires the accompanying hunter to be able to come to the immediate aid of the apprentice and stay within a distance that permits uninterrupted, unaided visual and verbal contact. A person may accompany no more than two apprentice hunters while hunting.

## U.S. Military Personnel

Active-duty U.S. military personnel who have maintained resident status may receive any hunting license that does not require a separate application for free. The individual must present military ID, leave papers, duty papers, military orders or other evidence verifying that he or she is a member of the military, along with a valid Michigan driver's license or voter's registration card. The hunting licenses are available at all license agents and DNR Customer Service Centers.

## Pure Michigan Hunt

Winners of the 2014 Pure Michigan Hunt (PMH) may purchase one elk, bear, antlerless deer, spring turkey, and fall turkey hunting license at the cost of \$3 per license, except non-residents are not eligible to purchase the PMH elk license. Each PMH license is valid for the applicable 2014 species hunting season and may be used in any open hunt area for that species, except bear hunting on Drummond Island. Licenses shall be subject to all 2014 hunting regulations. PMH winners may also participate in one reserved waterfowl hunt at a managed

waterfowl area. Individuals who have received an elk license through a prior elk drawing are eligible to apply for the PMH. Purchase of PMH licenses does not affect the hunter's eligibility to apply for or purchase other hunting licenses, and will not affect bear preference points or weighted elk chances the hunter has earned. PMH applicants must be at least 10 years old and eligible to purchase regular (non-apprentice) hunting licenses. Hunters may purchase as many PMH applications as they wish until Dec. 31, 2013. Applications cost \$4 each. Drawing results will be posted at [www.michigan.gov/huntdrawings](http://www.michigan.gov/huntdrawings) on Jan. 27, 2014.

## Interstate Wildlife Violator Compact

Michigan is a member of the Interstate Wildlife Violator Compact, an agreement whereby participating states share information about fish and game violators and honor each other's decision to deny licenses and permits. If your hunting, fishing, or trapping license is revoked in Michigan, you may lose your privileges in Alabama, Alaska, Arizona, California, Colorado, Florida, Georgia, Idaho, Illinois, Indiana, Iowa, Kansas, Kentucky, Louisiana, Maryland, Minnesota, Missouri, Mississippi, Montana, Nevada, New Mexico, New York, North Dakota, Ohio, Oklahoma, Oregon, Pennsylvania, South Carolina, South Dakota, Tennessee, Texas, Utah, Vermont, Virginia, Washington, West Virginia, Wisconsin and Wyoming. And, if your license is revoked in any of these states, it also may be in Michigan.

## Hunter Education Program

Michigan has a long, rich tradition of hunting. In Michigan, hunting contributes to wildlife management and conservation, provides a positive family experience and increased recreational opportunity, and is good for the economy.

Safe hunting begins with hunter education. Michigan's hunter education program has had a dramatic impact on reducing hunting incidents in our state. Courses are offered year-round throughout the state, though most occur during August, September and October. The typical course consists of two sessions with a total class time of 10-12 hours. Students also can use the Internet to complete a part of the hunter education course. The online course can be found at [www.michigan.gov/huntereducation](http://www.michigan.gov/huntereducation).

If you are interested in becoming a hunter education instructor, please write to: Hunter Education Program, Marketing and Outreach, Recruitment and Retention, Department of Natural Resources, P.O. Box 30028, Lansing, MI 48909, or call 517-335-3418.

Hunting Seasons and Bag Limits 2013-2014					
Species	Bag Limit	Area	Season Dates	Notes	
<b>Cottontail Rabbit and Snowshoe Hare</b>	5 per day 10 combined in possession	Statewide	Sept. 15 - Mar. 31		<p><b>NOTES:</b></p> <ol style="list-style-type: none"> <li>1. Crows may be taken outside the open season during hunting hours in compliance with federal regulations, if these birds are causing a nuisance or creating a health hazard.</li> <li>2. See pg. 32 for antler restriction regulations statewide.</li> <li>3. Zones 1 and 2: 5 per day/10 in possession. Zone 3: 3 per day/6 in possession.</li> <li>4. See pg. 40 for zone 1 hunting area and December Pheasant season map.</li> <li>5. Shotguns must be plugged so they are capable of holding no more than three shells. A federal waterfowl stamp is not required to hunt woodcock. HIP endorsement is required. See pg. 41. See 2013 Waterfowl Hunting Digest.</li> <li>6. A firearm or combination license is valid for an antlered or antlerless deer during this season. See pgs. 26 and 30 for restrictions.</li> <li>7. See pgs. 26 and 30 for eligibility requirements.</li> <li>8. Special rules for Ionia and Highland field trial areas. See State Parks and Recreation Areas section on pg. 15.</li> <li>9. See sharp-tailed grouse map on pg. 39.</li> <li>10. Allegan State Game Area's Fenville Farm Unit and Muskegon County Wastewater are closed to the early goose season for 2013-2014.</li> </ol>
<b>Crow</b>	No Limit	Statewide	Aug. 1 - Sept. 30 and Feb. 1 - Mar. 31	1	
<b>Deer</b>	See pgs. 31 and 32 for U.P. and DMU 487 buck hunting and		antler point restriction regulations		
Early Antlerless Firearm	1 per kill tag	See Antlerless Digest	Sept. 21-22		
Liberty Hunt	1	See pg. 26 and 30	Sept. 21-22	2,6,7	
Independence Hunt	1	See pg. 30	Oct. 17-20	2,6,7	
Archery	1 per kill tag	Statewide	Oct. 1 - Nov. 14 and Dec. 1 - Jan. 1	2	
Regular Firearm	1 per kill tag	Statewide	Nov. 15-30	2	
Muzzleloading	1 per kill tag	Zone 1 Zone 2 Zone 3	Dec. 6-15 Dec. 13-22 Dec. 6-22	2	
Late Antlerless Firearm	1 per kill tag	See Antlerless Digest	Dec. 23 - Jan. 1		
<b>Pheasant (male only)</b>	2 per day 4 in possession	Zone 1 (partial) Zone 2, 3 Zone 3 (partial)	Oct. 10-31 Oct. 20 - Nov. 14 Dec. 1 - Jan. 1	4	
<b>Quail</b>	5 per day 10 in possession	See pg. 39	Oct. 20 - Nov. 14	8	
<b>Ruffed Grouse</b>	See note 3	Statewide	Sept. 15 - Nov. 14 and Dec. 1 - Jan. 1		
<b>Sharp-tailed Grouse</b>	2 per day 4 in possession 6 per season	See pg. 39	Oct. 10-31	9	
<b>Squirrel Fox and Gray (black phase included)</b>	5 per day 10 in possession	Statewide	Sept. 15 - Mar. 1		
<b>Early Goose</b>	5 per day 15 in possession	Zone 1, and Saginaw, Tuscola, & Huron Counties Zone 2, 3	Sept. 1-10 Sept. 1-15	10	
<b>Woodcock</b>	3 per day 6 in possession	Statewide	Sept. 21 - Nov. 4	5	
<ul style="list-style-type: none"> <li>• Opossum, porcupine, weasel, red squirrel, skunk, ground squirrel, woodchuck, feral swine, feral pigeons, starling and house sparrows may be taken year-round with a valid Michigan hunting license. See the state park and recreation area restrictions on pg. 15.</li> <li>• For nighttime hunting see pg. 54-55.</li> </ul>			<p><b>Seasons and bag limits for waterfowl, bear, wolf, turkey, and elk are published in separate species-specific digests.</b></p>		

**PURE MICHIGAN HUNT**

**APPLY TODAY** for a multi-species hunt and prize package valued at over **\$4,000!**

Each application only \$4.  
Visit [www.michigan.gov/puremichiganhunt](http://www.michigan.gov/puremichiganhunt)

Species	Bag Limit	Area	Season Dates	Notes
<b>Fur Harvester - Trapping Seasons</b>				
<b>Muskrat and Mink</b>	No limit	Zone 1 Zone 2 Zone 3	Oct. 25 - Mar. 1 Nov. 1 - Mar. 1 Nov. 10 - Mar 1	9
<b>Raccoon</b>	No limit	Zones 1 & 2 Zone 3	Oct. 15 - Jan. 31 Nov. 1 - Jan. 31	1,9
<b>Gray and Red Fox and Coyote</b>	No limit	Statewide	Oct. 15 - Mar. 1	1,5,9
<b>Bobcat</b>	See pg. 52	Units A & B Units C, D, E, & F	Dec. 1 - Feb. 1 Dec. 10-20	6,8,9
<b>Badger</b>	1 per person	Zones 1 & 2 Zone 3	Oct. 15 - Nov. 14 Nov. 1 - Mar. 1	4,9
<b>Fisher/Marten</b>	1 fisher <b>or</b> 1 marten per person	Zone 1 (see note 7)	Dec. 1-15	6,7,9
<b>Beaver and Otter<sup>6</sup></b>	See pg. 51	Units A,B & C	See pg. 51	9
<b>Fur Harvester - Hunting Seasons</b>				
<b>Bobcat</b>	See pg. 52	Units A,B & C Unit D Unit E & F	Jan. 1 - Mar. 1 Jan. 1 - Feb. 1 Jan. 1 - Jan. 11	6,9
<b>Gray and Red Fox</b>	No limit	Statewide	Oct. 15 - Mar. 1	2,9
<b>Raccoon</b>	No limit	Statewide	Oct. 1 - Jan. 31	1,2,9
<b>Coyote</b>	No limit	Statewide	Jul. 15 - Apr. 15	1,2,3,9
<b>Nighttime Raccoon and Predator - Hunting Seasons</b>				
<b>Raccoon</b>	No limit	Statewide	Oct. 1 - Jan. 31	2,9
<b>Opossum</b>	No limit	Statewide	Sept. 15 - Mar. 31	2,9
<b>Gray and Red Fox</b>	No limit	Statewide	Oct. 15 - Mar. 1	2,9
<b>Coyote</b>	No limit	Statewide	Oct. 15 - Apr. 15	2,3,9

**NOTES:**

- Raccoon and Coyote may be taken on private property by a property owner or designee all year if they are doing or about to do damage on private property. A license or written permit is not needed.
- See Nighttime Raccoon and Predator Hunting on pg. 54-55 for specific regulations governing hunting these species at night.
- Residents possessing a valid small game license may hunt coyote during the established season.
- In Zone 1, badger may be trapped only in Baraga, Dickinson, Gogebic, Houghton, Iron, Keweenaw, Marquette, Menominee and Ontonagon counties, and Alger and Delta counties west of the federal forest Hwy-13. Badgers do not require registration.
- See Winter Fox and Coyote Non-lethal Cable Restraints on pg. 53 for regulations governing the trapping of fox and coyote.
- This species requires a free kill tag. See furbearer Kill Tags on pg. 44 for details.
- Fisher and marten are open in Zone 1 excluding Drummond Island
- Bobcat units C & D are open only on private land using only foothold traps. Units E & F are open to public and private land but limited to foothold traps only.
- For nonresident hunting see pg. 44.

**Hunting and Trapping and Firearm Zones**

Michigan is divided into Hunting and Trapping Zones 1-2-3. Zone 1 includes all of the Upper Peninsula. The dividing line between Zones 2 and 3 is: From the Lake Michigan shoreline north of Muskegon Lake easterly on Memorial Drive to Ruddiman Drive to Lake Avenue, easterly on Lake Avenue to M-120 in North Muskegon, northeasterly on M-120 to M-20, easterly on M-20 to



US-10, easterly on US-10 to Garfield Road in Bay County, northerly on Garfield Road to Pinconning Road, easterly on Pinconning Road to Seven Mile Road, northerly on Seven Mile Road to Lincoln School Road (County Road 25) in Arenac County, northerly on Lincoln School Road to M-61, easterly on M-61 to US-23, easterly on US-23 to center line of AuGres River, southerly along center line of AuGres River to Saginaw Bay, easterly 90 degrees east for 7 miles into Saginaw Bay, then northerly 78 degrees east to the International Boundary.

**Exception:** The waterfowl hunting zone lines differ from those above. Refer to the 2013-2014 Waterfowl Hunting Digest for waterfowl zone descriptions.

Michigan is also divided into a northern rifle zone where rifles may be used for firearm deer hunting and a southern shotgun zone where only shotguns, muzzleloading firearms and certain handguns may be used for deer hunting (see pg. 20). The dividing line between the northern rifle deer hunting zone and the southern shotgun zone is as follows: Starting at a point on the Lake Michigan shoreline directly west of M-46, then easterly to M-46, then easterly along M-46 to US-131 at Cedar Springs, southerly on US-131 to M-57, easterly on M-57 to Montcalm Road on the Kent-Montcalm county line, southerly on Montcalm Road and the Kent-Ionia county line to M-44, easterly on M-44 to M-66, northerly on M-66 to M-57, easterly on M-57 to M-52 near Chesaning, northerly on M-52 to M-46, easterly on M-46 to M-47, northerly on M-47 to US-10 west of Bay City, easterly on US-10 to I-75, northerly on I-75 and US-23 to Beaver Road (about 1 mile north of Kawkawlin), easterly to Saginaw Bay, north 50 degrees east to the International Boundary.

### Hunting Hours

Below is a map of the hunting-hour time zones. Actual legal hunting hours for bear, deer, fall wild turkey, furbearer and small game for Time Zone A are shown in the table at right. Hunting hours for migratory game birds are different and are published in the 2013-2014 Waterfowl Hunting Digest.

To determine the opening (a.m.) and closing (p.m.) time for any day in another time zone, add the minutes shown below to the times listed in the Time Zone A Hunting Hours Table.

The hunting hours listed in the table reflect Eastern Standard Time, with an adjustment for daylight-saving time. If you are hunting in Gogebic, Iron, Dickinson or Menominee counties (Central Standard Time), you must make an additional adjustment to the printed time by subtracting one hour.

### Time Zone A. Bear, Deer, Fall Wild Turkey, Furbearer and Small Game Hunting Hours Table\*

One-half hour before sunrise to one-half hour after sunset (adjusted for daylight saving time).

For hunt dates not listed in the table, please consult your local newspaper or the DNR website at [www.michigan.gov/hunting](http://www.michigan.gov/hunting).

2013	Sept.		Oct.		Nov.		Dec.	
Date	A.M.	P.M.	A.M.	P.M.	A.M.	P.M.	A.M.	P.M.
1	6:28	8:36	7:00	7:43	7:36	6:55	7:12	5:31
2	6:29	8:34	7:01	7:42	7:37	6:54	7:13	5:30
3	6:30	8:33	7:02	7:40	6:39	5:53	7:14	5:30
4	6:31	8:31	7:03	7:38	6:40	5:52	7:15	5:30
5	6:32	8:29	7:04	7:36	6:41	5:50	7:16	5:30
6	6:33	8:27	7:05	7:35	6:42	5:49	7:17	5:30
7	6:34	8:26	7:06	7:33	6:44	5:48	7:18	5:30
8	6:35	8:24	7:08	7:31	6:45	5:47	7:19	5:30
9	6:36	8:22	7:09	7:30	6:46	5:46	7:20	5:30
10	6:37	8:20	7:10	7:28	6:47	5:45	7:21	5:30
11	6:38	8:19	7:11	7:26	6:49	5:44	7:22	5:30
12	6:39	8:17	7:12	7:25	6:50	5:43	7:23	5:30
13	6:40	8:15	7:13	7:23	6:51	5:42	7:23	5:30
14	6:41	8:13	7:14	7:22	6:52	5:41	7:24	5:30
15	6:43	8:12	7:16	7:20	6:54	5:40	7:25	5:31
16	6:44	8:10	7:17	7:18	6:55	5:39	7:25	5:31
17	6:45	8:08	7:18	7:17	6:56	5:38	7:26	5:31
18	6:46	8:06	7:19	7:15	6:57	5:38	7:27	5:32
19	6:47	8:04	7:20	7:14	6:58	5:37	7:27	5:32
20	6:48	8:03	7:21	7:12	7:00	5:36	7:28	5:32
21	6:49	8:01	7:23	7:11	7:01	5:35	7:28	5:33
22	6:50	7:59	7:24	7:09	7:02	5:35	7:29	5:33
23	6:51	7:57	7:25	7:08	7:03	5:34	7:29	5:34
24	6:52	7:56	7:26	7:06	7:04	5:34	7:30	5:35
25	6:53	7:54	7:27	7:05	7:06	5:33	7:30	5:35
26	6:54	7:52	7:29	7:03	7:07	5:33	7:30	5:36
27	6:55	7:50	7:30	7:02	7:08	5:32	7:31	5:37
28	6:56	7:49	7:31	7:01	7:09	5:32	7:31	5:37
29	6:58	7:47	7:32	6:59	7:10	5:31	7:31	5:38
30	6:59	7:45	7:34	6:58	7:11	5:31	7:31	5:39
31			7:35	6:57			7:32	5:40

- \*Exceptions:**
- Woodcock hunting hours are sunrise to sunset.
  - Spring turkey hunting hours are one-half hour before sunrise to one-half hour before sunset. See the 2014 Spring Wild Turkey Hunting Digest for legal hunting hours.
  - Waterfowl hunting hours are one-half hour before sunrise to sunset. See the 2013-2014 Michigan Waterfowl Hunting Digest for legal hunting hours.

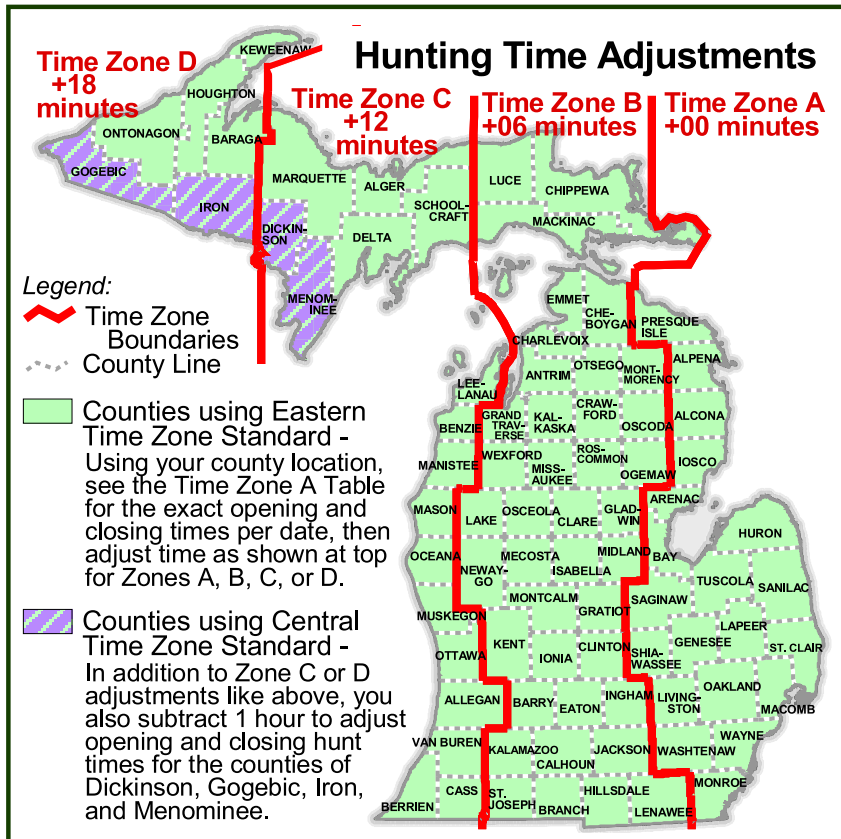

## Public Hunting Lands Information Available Online

Looking for a place to hunt? The DNR has created a collection of maps at [www.michigan.gov/gohunt](http://www.michigan.gov/gohunt) that identify all lands that are open to public hunting in Michigan.

Hunters can click on a particular county and see not only the state forest, wildlife management, and parks and recreation lands open to hunting that are administered by the DNR, but also all federal lands as well as private lands that are open to the public through the Hunting Access Program (HAP) or the Commercial Forest Act (CFA). It is the responsibility of the users of these maps to be aware of all regulations relevant to their hunting activities and hunting locations. These maps show approximate boundaries of lands open to public hunting.

## Private Lands Open to Public Hunting

### Commercial Forest (CF) Lands

Over 2.2 million acres of privately owned forests enrolled in the CF program are accessible by foot to the public for fishing and hunting. Use of motorized vehicles for fishing and hunting access is at the landowner's discretion. The CF lands are not posted or signed as commercial forests and may be fenced and/or gated. The presence of a fence or gate does not prohibit public access to CF lands for fishing or hunting. The owner may restrict public access during periods of active commercial logging to ensure public safety. Other than foot access for the acts of hunting or fishing, activities such as (but not limited to) camping, leaving anything unattended (e.g. bait, blinds, traps, etc.), and damaging or injuring vegetation (e.g. cutting/ nailing), require the landowner's permission.

Commercial activity on CF lands is not allowed for any purpose other than forestry or oil and gas extraction. Legal land descriptions of lands listed in this program are available on the DNR website at [www.michigan.gov/gohunt](http://www.michigan.gov/gohunt), under "Where Can I Hunt?" If you have questions about this program or specific CF lands, contact the nearest DNR office or DNR Forest Resources Division, P.O. Box 30452, Lansing, MI 48909.

### Hunting Access Program (HAP) Properties

Michigan's Hunting Access Program (HAP) was created in 1977 to increase public hunting opportunities in southern Michigan, where 97 percent of the land base is in private ownership. This program is now one of the oldest dedicated private-lands public access programs in the nation. Providing access to quality hunting lands close to urban centers is a key component to offering additional hunting opportunities, as well as attracting new and retaining current hunters.



For further details, consult the Public Hunting on Private Lands 2013-2014 digest, which is available at DNR offices and license agents, or visit the HAP website at [www.michigan.gov/hap](http://www.michigan.gov/hap). Aerial photographs of HAP farms can be viewed on the DNR's interactive mapping tool, Mi-HUNT, [www.michigan.gov/mihunt](http://www.michigan.gov/mihunt).

### Hunting and Trapping in State Parks and Recreation Areas

All state parks and recreation areas are closed to hunting from Apr. 1 - Sept. 14, except in areas designated open during the early Canada goose season and spring wild turkey season. Contact the individual park for hunting information. Quail may be harvested only by field trial participants in the Highland and Ionia Recreation Area field trial areas on days with authorized field trials. Contact the area headquarters for field trial dates.

It is illegal to target shoot in a state park or recreation area, except on designated shooting ranges at Bald Mountain, Island Lake, Ortonville and Pontiac Lake recreation areas. To make camping reservations, go to [www.midnrreservations.com](http://www.midnrreservations.com). Michigan residents have the opportunity to buy a Recreation Passport for \$11 when renewing their vehicle registration with the Secretary of State. The Recreation Passport gives you access to all 101 state parks and recreation areas, state forest campgrounds, and all DNR-administered boat launches in Michigan. Camping fees remain in effect. For more information visit [www.michigan.gov/recreationpassport](http://www.michigan.gov/recreationpassport) or call 517-373-9900. Out-of-state registered vehicles will require a daily (\$8.40) or annual (\$30.50) fee to enter any state park or DNR-administered boat launch site.

There is no trapping within 50 feet of the mowed portions of specific areas within state park and recreation areas. Check with the park headquarters for current trapping regulations and any restrictions for those areas prior to trapping.

### Additional Privately Owned Lands Open to Public Hunting

Hunting rights have been purchased by the state of Michigan for various privately owned lands. These lands are open to public hunting. Registration is not required, but all applicable laws still apply. For additional information and a complete legal description of these parcels, refer to the DNR website at [www.michigan.gov/gohunt](http://www.michigan.gov/gohunt).

### Hunters Helping Landowners

The Hunters Helping Landowners Program, allows hunters to voluntarily enroll and indicate two counties where they would like to hunt antlerless deer on private lands. Upon request from landowners wishing to participate in this program, the DNR will provide a list of volunteer antlerless deer hunters. For more information about this program or to enroll as a volunteer hunter, please visit [www.michigan.gov/hhl](http://www.michigan.gov/hhl).



### The Michigan Natural Resources Trust Fund

Providing funding for outdoor recreation, including public hunting lands, for more than 35-years.  
[www.michigan.gov/dnr-grants](http://www.michigan.gov/dnr-grants)



## Safety Zones Around Buildings

Safety zones are all areas within 150 yards (450 feet) of an occupied building, house, cabin, or any barn or other building used in a farm operation. No person, including archery and crossbow hunters, may hunt or discharge a firearm, crossbow or bow in a safety zone, or shoot at any wild animal or wild bird within a safety zone, without the written permission of the owner or occupant of the property. The safety zone applies to hunting only. It does not apply to indoor or outdoor shooting ranges, target shooting, law enforcement activities or the discharge of firearms, crossbows or bows for any non-hunting purpose.

## Hunting and Trapping Within a Road or Railroad Right-of-Way

You may hunt and trap within a road right-of-way where the adjoining property is publicly owned. If the adjacent property is privately owned, you must have permission from the landowner. Railroad rights-of-way are private property. Trespassing on railroad property is a misdemeanor. You must have written permission from the railroad company to be exempt from trespass. Also see the Hunting on National Forest Lands section on pg. 62.

## Float Hunting

Hunting and trapping are exclusive rights of landowners bordering the waterways and their invited guests. You must secure permission from the landowner before float hunting or setting traps along those waterways that are protected by the recreational trespass law. You may float hunt and trap on and along waterways that are surrounded by public land and open to hunting.

## Townships with Hunting Restrictions

Townships or parts of townships in these counties are closed to hunting or restricted to types of firearms or the discharge of firearms as posted: Alcona, Arenac, Barry, Berrien, Crawford, Dickinson, Eaton, Emmet, Genesee, Iosco, Jackson, Kalamazoo, Livingston, Macomb, Manistee, Mason, Oakland, Otsego, Ottawa, Presque Isle, Saginaw, St. Clair, Washtenaw and Wayne. These areas are posted with the restrictions. For descriptions, contact the appropriate township clerk or township police department.

## Trespassing on Private Land

Trespassing is illegal and erodes support for recreational hunting. Written or verbal permission is required from the landowner or leaseholder before you hunt on any farm lands or connected woodlots or on any posted private land. Hunters are required to produce their hunting license to landowners upon request. If you wound an animal or bird and it runs or flies onto private property, you have no legal right to pursue it without permission of the landowner and would be subject to prosecution.

## Hunter Orange Clothing Requirements

Except as noted below, you may not hunt with any device, or trap with any firearm, on any lands during daylight hunting hours from Aug. 15 - Apr. 30 unless you wear a hat, cap, vest, jacket or rain gear of highly visible orange color, commonly referred to as hunter orange. When hunting in any season with a license that authorizes the use of a firearm, you must wear hunter orange. During the November firearm deer season, this law applies to all deer hunters, including those hunting with a bow and arrow. The garment featuring hunter orange must be the outermost garment and must be visible from all sides. Camouflage orange garments, with 50 percent or more of the surface in hunter orange, are legal.

**Exception:** This law does not apply to those hunting waterfowl, crow, wild turkey, or to those engaged in the sport of falconry. It does not apply to archery or crossbow bear hunters or to those who are stationary and in the act of hunting bobcat, coyote or fox. Archery and crossbow deer hunters also are not required to wear hunter orange except during the youth firearm seasons, early antlerless firearm season and the November firearm deer season.

## Rifles in the Shotgun Zone

Centerfire or rimfire rifles may be used Dec. 1 - Nov. 9 in the Shotgun Zone (see pg. 11) during the open season for all species except, no rifles may be used for deer, turkeys and migratory game birds.

## Shell Capacity for Shotguns and Centerfire Rifles

It is unlawful to hunt with a semi-automatic shotgun or semi-automatic rifle that can hold more than six shells in the barrel and magazine combined, unless it is a .22 caliber rimfire. Fully automatic firearms are illegal. All shotguns used for migratory game birds (including woodcock) must be plugged so the total capacity of the shotgun does not exceed three shells.

## Crossbows

Any licensed hunter who has obtained a free crossbow stamp can hunt with a crossbow during any season in which a firearm is allowed, for both big and small game, except hunters in the Upper Peninsula may not use a crossbow or a modified bow during the Dec. 1 - Jan. 1 late archery deer season and Dec. 6-15 muzzleloader deer season, unless the hunter is disabled and has a crossbow permit or special permit to take game with a modified bow see pg. 28.

Any licensed hunter may use a crossbow throughout the archery deer season in the Lower Peninsula (Oct. 1 - Nov. 14 and Dec. 1 - Jan. 1) and during the early archery deer season in the Upper Peninsula (Oct. 1 - Nov. 14). Crossbow use is not allowed in the Red Oak Unit during the archery-only bear season (Oct. 6-12) except for certified hunters with a disability.

continued on next page

**continued**

When hunting deer, bear, elk, wolf and turkey, crossbow hunters must use only arrows, bolts, and quarrels with a broadhead hunting type of point not less than 7/8 of an inch wide and with a minimum of 14 inches in length.

**Transporting Firearms, Crossbows, and Bows and Arrows**

These rules apply whether your vehicle is parked, stopped, moving or is on private or public property. Firearms must be unloaded in the barrel, and all arrows must be in a quiver when a hunter is afield outside the legal hunting hours.

At all times when carried in or on a motor vehicle, including snowmobiles:

- Rifles, shotguns, muzzleloaders and other firearms must be unloaded in both barrel and magazine and enclosed in a case or carried in the trunk of a vehicle.
- Crossbows, slingshots and bows and arrows must be enclosed in a case or unstrung or carried in the trunk of a vehicle.

At all times, when carried in or on an off-road vehicle (ORV):

- Rifles, shotguns, muzzleloading and other firearms must be unloaded in both barrel and magazine and enclosed in a case or equipped with and made inoperative by a manufactured key-locked trigger-housing mechanism.
- Crossbows, slingshots and bows and arrows must be enclosed in a case or unstrung.

At all times, when carried in or on a motor-propelled boat or sailboat:

- Rifles, shotguns, muzzleloading and other firearms must be unloaded in both barrel and magazine.
- Firearms may not be loaded.

**Exception:** See the 2013-2014 Waterfowl Hunting Digest, under the Joint State-Federal Migratory Bird Hunting Regulations section.

**Exception:** These rules do not apply to a pistol carried under authority of a concealed pistol license or properly carried under authority of a specific exception from the requirement of a concealed pistol license. See Statewide Handgun Regulations on pgs. 20-21.

**Note:**

- A percussion cap muzzleloading longarm is considered unloaded if the percussion cap is removed.
- A flintlock muzzleloading longarm is considered unloaded if the cock is left down and the pan is empty.
- Black powder handguns must be transported as stated above.
- A muzzleloading firearm that has an electric ignition system is considered unloaded if the battery is removed.

**Bringing Equipment Afield During Furbearer Hunting and Trapping Seasons**

See pgs. 44-55

**Bringing Equipment Afield During Deer Seasons****Archery Deer Seasons**

During the archery deer seasons, it is illegal to carry afield a pistol, revolver or other firearm while bow hunting for deer.

**Exceptions:** This prohibition does not apply to pistols carried under authority of a concealed pistol license or properly carried under authority of a specific exception from the requirement of a concealed pistol license. However, a concealed pistol license does not authorize the individual to use the pistol to take game except as provided by law.

**November 10-14**

It is unlawful to carry afield or transport any rifle (including rimfire) or shotgun if you have buckshot, slug, ball loads or cut shells.

**Exception:** You may transport a firearm to your deer camp or to a target range during this period if the firearm is properly transported. A resident who holds a fur harvester license may carry a .22 caliber or smaller rimfire firearm while hunting furbearers or checking a trap line during the open season for hunting or trapping furbearing animals. You also may target shoot on your own property provided there is no attempt to take game.

**Firearm Deer Season**

It is illegal for a person taking or attempting to take game to carry or possess afield a centerfire or muzzleloading rifle, a crossbow, a bow and arrow, a centerfire or black powder handgun, or a shotgun with buckshot, slug or ball loads or cut shells, unless you have in your possession a 2013 firearm deer, combination deer or antlerless deer license for the appropriate DMU, with an unused kill tag issued in your name, or a 2013 firearm deer, combination deer or antlerless deer license for the appropriate DMU issued in your name with an unused Deer Management Assistance (DMA) permit kill tag or an unused managed deer hunting permit.

**Muzzleloading Deer Seasons**

During the December muzzleloading seasons, muzzleloading deer hunters can carry afield and use only a crossbow (except in the Upper Peninsula) or a muzzleloading rifle, a muzzleloading shotgun, or a black powder handgun loaded with black powder or a commercially manufactured black powder substitute. Only certified hunters with a disability may use a crossbow or a modified bow during the muzzleloading season in the Upper Peninsula.

**All Firearm Deer Seasons-Rifle Zone** (See pg. 11)

In the rifle zone, deer may be taken with handguns, rifles, crossbows, bows and arrows, shotguns and muzzleloading firearms, including black powder handguns. It is legal to hunt deer in the rifle zone with any caliber of firearm except a .22 caliber or smaller rimfire (rifle or handgun). During the firearm deer seasons, a firearm deer hunter may carry afield a bow and arrow, crossbow and firearm.

**Exception:** See Muzzleloading Deer Seasons (pg. 19) for restrictions during this season.

**All Firearm Deer Seasons-Shotgun Zone** (See pg. 11)

In the shotgun zone, all hunters afield from Nov. 15-30, and all deer hunters in this zone during other deer seasons, must abide by the following firearm restrictions or use a crossbow or a bow and arrow. Legal firearms are as follows:

- A shotgun may have a smooth or rifled barrel and may be of any gauge.
- A muzzleloading rifle or black powder handgun must be loaded with black powder or a commercially manufactured black powder substitute.
- A conventional (smokeless powder) handgun must be .35 caliber or larger and loaded with straight-walled cartridges and may be single- or multiple-shot but cannot exceed a maximum capacity of nine rounds in the barrel and magazine combined.
- During the firearm deer seasons, a firearm deer hunter may carry afield a bow and arrow, crossbow and firearm. Exceptions: See Muzzleloading Deer Seasons above for restrictions during this season.
- Centerfire or rimfire may be used Dec. 1 - Nov. 9 in the shotgun zone during the open seasons. **Exception:** Rifles may NOT be used for deer, turkeys, migratory game birds and certain furbears (see pgs. 54-55 for Nighttime Raccoon and predator hunting and pg. 46-47 for furbearer restrictions).

**Statewide Handgun Regulations**

The rules listed below may not apply to those having a concealed pistol license (CPL) or specifically exempt by law from a CPL and carrying their handgun in accordance with their license or exemption.

- A person must be at least 18 years of age to hunt with or possess a handgun.
- Handguns cannot be borrowed or loaned to another person other than provided for under the CPL.
- While in the field, handguns must be carried in plain view.
- Carrying a handgun in a holster in plain view is permitted.
- You may transport your registered handguns while en route to and from your hunting or target shooting area; however, handguns, including BB guns larger than .177 caliber and all pellet guns, must be unloaded, in the barrel and magazines, and in a closed case designed for the storage of firearms and cannot be readily accessible to any occupant of the vehicle.

- It is a crime for certain felons to possess firearms, including rifles and shotguns, in Michigan.
- Nonresidents must have a CPL or a license to purchase, carry or transport issued by their home state in their possession in order to legally carry or transport a handgun in Michigan. For more information regarding statewide handgun regulations, obtaining a CPL, or concealed weapons and firearms laws, contact your local police department.

**Artificial Lights and Shining**

It is illegal to use an artificial light (including vehicle headlights) to locate wild animals at any time during November and all other days of the year between 11 p.m. and 6 a.m. It is illegal to use an artificial light on a highway or in a field, wetland, woodland or forest while having in your possession or control a bow and arrow, firearm or other device capable of shooting a projectile.

**Exception:** This prohibition does not apply to pistols carried under the authority of a concealed pistol license or properly carried under authority of a specific exemption from the requirement of a concealed pistol license. This does not authorize the individual to use the pistol to take game except as provided by law.

An artificial light may be used from Nov. 1-30 on property you own or property owned by a member of your immediate family if you do not have in your possession or control a bow and arrow, firearm or other device capable of shooting a projectile. It is a violation of federal law to shine at any time on any national wildlife refuge. Deer hunters may use an artificial light one hour before and one hour after shooting hours while carrying an unloaded firearm or bow and arrow when traveling on foot to or from their hunting location. See Nighttime Raccoon and Predator Hunting on pg. 54-55, for artificial light regulations when hunting raccoon, opossum, fox and coyote at night. Those not possessing a firearm or bow and arrow while traveling on foot may use lights during dog training or field trials to follow dogs chasing raccoon, opossum or fox. A lighted pin sight on a bow or a scope with illuminated crosshairs may be used to hunt game during legal hunting hours.

**Note:** If you are using an artificial light to locate game, you must immediately stop your vehicle when signaled by a uniformed officer or marked patrol vehicle.



## Restrictions on Off-Road Vehicles and Snowmobiles

At all times it is illegal to operate an off-road vehicle (ORV) on public lands in the Lower Peninsula unless posted open. Snowmobiles and ORVs are prohibited at any time on state game areas or state parks and recreation areas unless posted open.

**Time Restrictions**—It is illegal to operate an ORV or a snowmobile between the hours of 7 to 11 a.m. and 2 to 5 p.m. on any area open to public hunting during the Nov. 15-30 firearm deer season.

**Exceptions:** The time restrictions on the use of ORVs and snowmobiles do not apply during an emergency or while traveling to and from a permanent residence or hunting camp that is otherwise inaccessible by a conventional wheeled vehicle. The time restrictions on the use of ORVs also do not apply to those retrieving a legally taken deer, to private landowners and their invited guests, to motor vehicles licensed under the Michigan Vehicle Code operating on roads capable of sustaining automobile traffic, to a person with a disability using a designated trail or forest road for hunting or fishing purposes, or to a person with a valid permit to hunt from a standing vehicle.

## Raised Platforms and Tree Stands

The following persons may hunt from a raised platform or tree stand:

- All bow and crossbow hunters.
- Bear, deer, and wolf hunters when using a firearm.
- Fox and coyote hunters from one-half hour before sunrise to one-half hour after sunset.

All other firearm hunters are prohibited from using a raised platform or tree stand. A raised platform means a horizontal surface, constructed or manufactured by a person, that increases the field of vision of a person using it beyond the field of vision that normally would be attained by that person standing on the ground.

If you hunt on public land, your tree stand must be portable and your name and address must be affixed in legible English that can be easily read from the ground. Hunting platforms cannot be affixed or attached to any tree by nails, screws or bolts; however, a “T” bolt or similar device supplied by a tree stand manufacturer can be used.

Screw-in tree steps are illegal on public lands. It is illegal to use any item that penetrates through the bark of a tree in the construction or affixing of any device to assist in climbing a tree.

Scaffolds, raised platforms, ladders, steps and any other device to assist in climbing a tree cannot be placed on public lands any earlier than Sept. 1, and must be removed by March 1. A permanent raised platform or tree stand may be used for hunting on private land with the permission of the landowner.

It is unlawful to use an illegal tree stand, scaffold, step, etc., regardless of who placed it on public lands. Your name on a tree stand or ground blind on public land does not guarantee exclusive use.

## Ground Blinds on Public Land

*The Natural Resource Commission may be changing this section (Ground Blinds on Public Land) within the Wildlife Conservation Order before the 2013 fall hunting seasons. Please check the DNR website for any changes prior to the hunting seasons.*

A ground blind means a structure, enclosure or any material, natural or manufactured, placed on the ground to assist in concealing or disguising the user for the purpose of taking an animal. Any ground blind on public land that does not meet the requirements of either Type 1, 2, or 3 described below is an illegal ground blind.

**Exception:** See the 2013-2014 Waterfowl Hunting Digest (available Sept. 2013) for regulations on waterfowl hunting blinds.

### Only the following types of ground blinds are legal on public land:

**Type 1 (Portable Ground Blind).** This blind must be clearly portable and removed at the end of each day’s hunt. Fasteners, if used to attach or anchor the blind, cannot penetrate the cambium of a tree and also must be removed daily. No identification is required. These blinds may be used for legal hunting on public land, including all state game areas, state parks and state recreation areas in Zone 3 (see pg. 11).



**Type 2 (Dead Natural Materials Ground Blind).** This blind must be constructed exclusively of dead natural materials found in the area of the blind, except that a hunter may add netting, cloth, plastic or other materials for concealment or protection from the weather if these materials are not permanently fastened to the blind and are removed at the end of each day’s hunt.

These items can be tied to the blind but cannot be stapled, nailed, glued or fastened in any permanent manner. No identification is required. Fasteners (nails, screws, etc.) cannot be used in construction. These blinds may be used for legal hunting on public land, including all state game areas, state parks and state recreation areas in Zone 3 (see pg. 11).

continued on next page

**continued**

**Type 3 (Constructed Ground Blind).** This includes all other blinds not meeting the requirements of either Type 1 or Type 2, including portable ground blinds, if not removed daily.

Bear hunters may place constructed ground blinds on state lands in bear management units open to bear hunting for which they have a bear license beginning Aug. 10 in Zone 1 units and beginning Aug. 17 in Zone 2 units. Blinds must be removed within five days of a bear being harvested, or within five days of the end of the bear season for which the hunter has a license. Constructed ground blinds on all Zone 1 and Zone 2 public lands for deer hunting shall remain legal from Nov. 6 to the end of the annual deer season. In addition to being subject to criminal penalties, any constructed blind found on public land prior to Nov. 6 or after the end of the annual deer season will be considered abandoned.

The name and address of the person placing a constructed ground blind on public land must be permanently attached, etched, engraved or painted on the blind. These blinds are not legal on state game areas, state parks and state recreation areas in Zone 3 (see pg. 11). Fasteners, if used to anchor or attach the blind, cannot penetrate the cambium of a tree and must be removed with the blind. It is unlawful to use an illegal ground blind, regardless of who placed it on public land.

**Note:** If a person's Type 3 ground blind has been permitted to be placed on land administered by a local public agency (city, township, county), the local agency will establish the length of time that a blind may be placed on its property.

### Mandatory Penalties for Certain Hunting Violations

Violation of permits, season, bag limits, shooting hours and methods of taking game	\$50 to \$500 fine and/or up to 90 days in jail.
Illegal taking/possession of deer, bear or wild turkey	\$200 to \$1,000 fine and 5 to 90 days in jail, \$1,500 for bear, \$1,000 for deer/turkey, plus revocation of hunting licenses for remainder of year convicted, plus next three consecutive years.
Illegal use of artificial light with bow and arrow, crossbow, or firearm	\$100 to \$500 fine and/or 90 days in jail, plus revocation of hunting licenses for remainder of year convicted, plus next consecutive year.
Carrying a firearm while under the influence of alcohol or drugs	\$500 fine and/or up to 93 days in jail.
Multiple offender: Three convictions within preceding five years	\$500 to \$2,000 fine and 10 to 180 days in jail.

### Mentored Youth Hunting Program

The Mentored Youth Hunting Program allows youth hunters 9 years old and younger to hunt with a mentor who is at least 21 years old, has hunting experience and possesses a valid Michigan license to hunt other than an apprentice license. The mentored youth license is a "package" license to hunt small game, including waterfowl, turkey (spring and fall) and deer (two tags); trap furbearers and fish for all species. The mentor (adult) is limited to two hunting devices (shotgun, rifle, bow or crossbow) in the field while mentoring, and the youth hunter must be within arm's length of the mentor (adult) at all times. Any hunting device possessed by a mentored youth must be sized appropriately to fit the physical abilities of the youth. The mentor (adult) will be held responsible for all actions of the youth hunter while in the field.

A deer kill tag issued with the mentored youth license is valid for any deer in any deer management unit, except during antlerless-only seasons, when only an antlerless deer may be taken. See [www.michigan.gov/mentoredhunting](http://www.michigan.gov/mentoredhunting) for complete rules and restrictions.

### Rules for Young Hunters (Up to 16 Years of Age)

The following table explains which species youth are allowed to hunt, with an appropriate license. Nonresidents 16 years old and younger may purchase resident and junior licenses, except nonresident youth are not eligible to apply for a Michigan elk license.

Species and Age	9 or younger	10-13	14-16
<b>Small Game and Waterfowl</b>	Yes <sup>3</sup>	Yes <sup>1</sup>	Yes <sup>1</sup>
<b>Turkey</b>	Yes <sup>3</sup>	Yes <sup>1</sup>	Yes <sup>1</sup>
<b>Fur harvester<sup>4</sup></b>	Yes <sup>3</sup>	Yes <sup>1</sup>	Yes <sup>1</sup>
<b>Trap-only Fur harvester<sup>4</sup></b>	Yes	Yes	Yes
<b>Deer</b>	Yes <sup>2,3</sup>	Yes <sup>1,2</sup>	Yes <sup>1</sup>
<b>Bear</b>	No	Yes <sup>1,2</sup>	Yes <sup>1</sup>
<b>Elk</b>	No	Yes <sup>1,2</sup>	Yes <sup>1</sup>
<b>Wolf</b>	No	Yes <sup>1,2</sup>	Yes <sup>1,2</sup>

<sup>1</sup> If hunter safety-certified and accompanied by an adult 18 years old or older, or a youth apprentice with an apprentice license and accompanied by a parent, guardian or someone 21 or older (see Apprentice Hunting License on pg. 6). "Accompanied by" requires the adult to be able to come to the immediate aid of the apprentice and stay within a distance from the apprentice which allows uninterrupted, unaided visual and verbal contact. Apprentice licenses are not available for wolf hunting.

<sup>2</sup> Those younger than 14 years of age may hunt with archery and crossbow on public or private lands or with a firearm on private or Commercial Forest lands only.

<sup>3</sup> If in possession of a mentored youth hunting license and accompanied by an adult mentor 21 years old or older, with hunting experience, who has a valid Michigan hunting license other than an apprentice license. See additional requirements at [www.michigan.gov/mentoredhunting](http://www.michigan.gov/mentoredhunting).

<sup>4</sup> Must be age 8 or older to obtain kill tags for bobcat, otter, marten or fisher.

## Firearm Hunting Rules for Youth Deer Hunters

The following restrictions apply to youth hunters who participate in any firearm deer season:

- Youth under 14 years of age may hunt with archery and crossbow equipment on public or private lands or with a firearm on private or Commercial Forest lands only.
- A public-land antlerless deer license is required to hunt antlerless deer on Commercial Forest land.
- All hunters under age 17 must be accompanied by a parent, guardian or an adult designated by their parent or guardian; additional qualifications apply with the apprentice or mentored youth licenses.
- All hunters participating in firearm seasons must wear hunter orange.

## Junior Antlerless Deer Hunting License

Young hunters, ages 9 to 16, may purchase one junior antlerless deer license over the counter Jul. 15 - Aug. 15; however, a 9-year-old must be 10 by Sept. 15, 2013 to purchase this license. No application fee or drawing is required. This license is available only in Deer Management Units (DMUs) with a quota for antlerless licenses. This license may be purchased for either public or private land, not both. Nonresidents, ages 10 to 16, are allowed to purchase resident licenses. Also see the Firearm Hunting Rules for Youth Deer Hunters section above and 2013 Michigan Antlerless Deer Hunting Digest.

## Liberty Hunt - Youth

This firearm deer hunt will take place on all lands in Michigan Sept. 21-22, 2013. Youth 16 years of age or younger may participate in this hunt along with veterans with 100-percent disability (see pg. 30). Youth younger than 14 years of age may hunt with archery and crossbow on public or private land or with a firearm on private land only, regardless of license used. For youth 10 to 16 years old, valid licenses include a combination, firearm or antlerless deer license. Hunters under the age of 10 must be licensed through the mentored youth hunting program and accompanied by a qualified mentor.

During this two-day hunt, a firearm or combination license may be used for an antlered or antlerless deer. Antler Point Restrictions apply when taking an antlered deer, except on mentored youth license. A Deer Management Assistance (DMA) permit may also be used to take one antlerless deer only, if issued for the area/land upon which hunting. Archery and junior archery deer licenses are not valid for this hunt. The bag limit for this season is one deer. Eligible hunters with a firearm or combination license may take an antlered or antlerless deer during this special two-day season. All hunters participating in this season must wear hunter orange.

## Youth Waterfowl Weekend and Youth Waterfowl Hunting on Managed Waterfowl Areas

Youth Waterfowl hunting weekend will be Sept. 14-15, 2013 statewide for properly licensed youth ages 15 and younger. Youth 10 to 15 years old must have a small game license and be accompanied by a parent, guardian or someone 18 or older designated by the parent or guardian. Youth under 10 must be accompanied by an adult at least 21 years old, and the youth and adult must meet all the provisions of the Mentored Youth Hunting Program. The adult will not be allowed to hunt ducks, mergansers, coots, or moorhens and will not be required to have a waterfowl hunting license. The daily limit includes ducks, mergansers, geese, coots, and moorhens. The daily limits and species restrictions are the same as those allowed in the regular waterfowl hunting season. See the 2013-2014 Michigan Waterfowl Hunting Digest.

There are seven premier managed waterfowl hunting areas in southern Michigan that offer first-class waterfowl hunting opportunities, including youth hunting opportunities. Several areas offer opening day afternoon youth hunts, as well as other youth priority draws during the season. Opening weekend hunts are by reservation only at several areas. For details see the 2013 Waterfowl Reserved Hunt Application Digest. Visit [www.michigan.gov/wetlandwonders](http://www.michigan.gov/wetlandwonders) for more information on managed waterfowl hunting areas, and [www.michigan.gov/waterfowl](http://www.michigan.gov/waterfowl) for more details on waterfowl hunting regulations. Refer to the 2013-2014 Michigan Waterfowl Hunting Digest for youth hunting details, daily shooting hours, daily limits, and species restrictions.



## Michigan Veterans with Disabilities

A resident disabled veteran is eligible to obtain any hunting license which does not require a separate application free of charge if one of the following conditions is met:

- The person has been determined by the United States Department of Veterans Affairs to be permanently and totally disabled as a result of military service and entitled to veterans' benefits at the 100-percent rate, for a disability other than blindness.
- The person has been rated by United States Department of Veterans Affairs as individually unemployable.

**Documentation of eligibility from the Veterans Administration shall be in the possession of a veteran when using these licenses.**

## Crossbow Permits for Hunters with Disabilities

A person with a disability may apply for a crossbow permit. A physician can automatically certify a hunter as eligible for a crossbow permit if the hunter has an amputation involving body extremities required for stable function to use conventional archery equipment, or has a spinal cord injury resulting in permanent disability to the lower extremities, leaving the applicant permanently non-ambulatory, or has a permanent wheelchair restriction.

If none of the above criteria apply, physicians, physical therapists or occupational therapists can certify hunters who fail a functional draw test that equals 35 pounds of resistance and involves holding it for four seconds, or a manual muscle test involving the grading of shoulder and elbow flexion and extension, or an impaired range-of-motion test involving the shoulder or elbow. In addition, a physician can recommend a crossbow permit for other temporary or permanent disabilities, such as neuromuscular conditions. For more information and an application, call 517-373-1204.

## Modified Bow Permit

A person with a temporary or permanent disability who has the full use of only one arm may apply for a modified bow permit. This permit allows modifications to a compound bow, including the addition of an overdraw lock device allowing the bow to be held and shot with one arm. This modification may not convert a compound bow into a crossbow. For more information, go to [www.pcba-inc.org/](http://www.pcba-inc.org/).

## Hunters Using ORVs

Those holding a valid permit to hunt from a standing vehicle or those with disabilities hunting while using an off-road vehicle (ORV) may display an orange flag to identify themselves as hunters with disabilities.

## Use of Personal Assistive Mobility Device (PAMD)

An individual whose disability requires use of a wheelchair or PAMD may use such equipment anywhere foot travel is allowed on public land. Areas that prohibit the use of motorized vehicles are not off-limits to PAMDs. Individuals should use caution where the landscape is uneven or offers other safety concerns.

## Hunters who are Legally Blind

Legally blind hunters may use laser sighting devices to take game, subject to all other regulations, with a firearm or crossbow if all the following conditions are met:

- The person is accompanied by a sighted person who is at least 18 years of age and possesses proof of a current or previous hunting license (other than an apprentice license) or proof of successful completion of a hunter safety class;
- The legally blind person possesses the appropriate hunting license and proof of impairment in the form of a Secretary of State ID card. No permit is necessary for this accommodation.

## Permit to Hunt Using a Laser Sighting Device

Hunters with other permanent disabilities may apply to the DNR Law Enforcement Division for a permit to use a laser sighting device with a firearm or crossbow to take game. Subject to all other regulations, a permittee may take game with the use of a laser sighting device only if accompanied by a person who is at least 18 years of age who is licensed to hunt the same game (other than an apprentice license). For application information, please call 517-373-1230.

## Use of Ground Blinds on Public Land by Hunters with Disabilities

Any person who has been issued a permit to hunt from a standing vehicle, issued a permit to hunt with a crossbow, or who has been issued a disabled person parking permit by the Secretary of State, or who meets the disability standards set forth in the Michigan Off-Road Recreational Vehicle Law, may use a constructed ground blind on public land. If the constructed ground blind is left overnight on public land, the following conditions must be met:

- The blind is placed on public land no earlier than 10 days prior to the hunting season for which it is used and is removed at the end of the season for which it is used.
- The hunter with a disability has attached, etched, engraved or painted his or her name and address on the blind.
- Fasteners, if used to anchor or attach the blind, cannot penetrate the bark of a tree and must be removed with the blind.
- A non-disabled person can assist a hunter with a disability in constructing a legal blind on public land. **See note, on pg. 24 for removal exemption of ground blinds on local public lands.**

## Permit to Hunt from a Standing Vehicle

A person who, due to injury, disease, amputation or paralysis, is permanently disabled and unable to walk, may apply for a permit to hunt from a standing vehicle. This permit allows a person to hunt, and shoot from, a parked motor vehicle or ORV. Subject to all other regulations including buck limits and antler-point restrictions, this permit also entitles the holder to take a deer of either sex under any valid deer license.

## Independence Hunt

This firearm deer hunt will take place on private lands or public land requiring an access permit and open to the Independence Hunt by lottery from Oct. 17-20, 2013. Veterans with 100-percent disability or rated as individually unemployable by the U.S. Department of Veterans Affairs may participate in this hunt. In addition, hunters who possess a permit to hunt from a standing vehicle or to hunt using a laser-sighting device, and hunters who are legally blind may also participate.

During this hunt, a firearm or combination license may be used for an antlered or antlerless deer. Antler Point Restrictions apply when taking an antlered deer. The bag limit for this season is one deer. All hunters participating in this season must wear hunter orange.

## Liberty Hunt - Hunters With Disabilities

This firearm deer hunt will take place on all lands in Michigan Sept. 21-22, 2013. Disabled veterans and disabled individuals who qualify as stated below, along with youth ages 16 and younger (see pg. 26) may participate in this hunt. For qualified persons with disabilities, valid licenses include a combination, firearm or antlerless deer license.

During this two-day hunt, a firearm or combination license may be used for an antlered or antlerless deer. Antler Point Restrictions apply when taking an antlered deer, except on mentored youth license. A Deer Management Assistance (DMA) permit may also be used to take one antlerless deer only, if issued for the area/land upon which hunting. Archery and junior archery deer licenses are not valid for this hunt. The bag limit for this season is one deer. Eligible hunters with a firearm or combination license may take an antlered or antlerless deer during this special two-day season. All hunters participating in this season must wear hunter orange.

To qualify an individual must fit one of the following criteria:

- be a veteran who has been determined to have 100-percent disability, or is rated as individually unemployable by the U.S. Department of Veterans Affairs.
- have been issued a permit, by the DNR, to hunt from a standing vehicle.
- have been issued a permit by the DNR to hunt using a laser-sighting device.
- be blind as defined by MCL 393.351

## White-tailed Deer

**Antlered deer** means a deer having at least one antler that extends three inches or more above the skull.

**Antlerless deer** means a deer without antlers or with antlers where the longest antler extends less than three inches above the skull.

A person is limited to purchasing only two kill tags for taking an antlered (buck) deer. You may purchase one archery license AND one firearm license (one kill tag each) OR you may purchase one combination license (two kill tags).

**If you take two antlered deer, one of the two antlered deer must have at least one antler with four or more antler points one inch or longer.** This deer can be taken first or second in either an archery, firearm or muzzleloading season.

**Exception:** See U.P. and DMU 487 Buck Hunting Regulations and Antler Restriction Regulations on pg. 32.

## Upper Peninsula and DMU 487 Buck Hunting Regulations

Buck hunting regulations in the Upper Peninsula and Deer Management Unit (DMU) 487 depends upon the type of license purchased.

**Option 1** - "One Buck" Limit: Hunters possessing a firearm and/or archery deer license may take only ONE antlered deer in the Upper Peninsula and DMU 487, all seasons combined. Also see Antler Restriction Regulations on pg. 32.

**Option 2** - "Two Buck" Limit: Hunters possessing a combination deer license may take two antlered deer in the Upper Peninsula and DMU 487, all seasons combined, but additional antler point restrictions apply (see Antler Restriction Regulations on pg. 32).



The Pittman-Robertson Wildlife Restoration Act of 1937 created a funding mechanism for state wildlife agencies to restore and manage their wildlife resources. A federal excise tax on firearms and ammunition, bows and arrows is collected by the Internal Revenue Service and apportioned to states through a formula based on the number of licensed hunters and the size of each state.

Eligible states are those that have passed laws preventing the use of hunting license fees for any purpose other than managing the state's wildlife. The federal excise tax, along with hunter license fees, are used to acquire lands; protect, restore and manage wildlife habitats; manage wildlife populations; conduct wildlife research and surveys; provide hunter access; and develop, operate and maintain facilities and infrastructure necessary to manage wildlife resources. Additionally, a specific portion of the federal excise tax is dedicated for hunter education, and for developing and managing shooting ranges. Since its inception in 1937, Michigan's share of the Wildlife Restoration Funds has reached over \$275 million.



### Antler Restriction Regulations

The table below shows the antler restrictions required with specific deer licenses by area or Deer Management Unit (DMU). See map of DMU boundaries on pg. 37. **Exceptions:** If you are hunting deer in the Upper Peninsula or DMU 487, also see the Upper Peninsula and DMU 487 Buck Hunting Regulations on pg. 31.

License	1 antler at least 3" long	2 legal points on one side*	3 legal points on one side*	4 legal points on one side*
<b>Regular Combination Deer License</b>	Lower Peninsula except DMUs 005, 010, 015, 024, 028, 040, 043, 045, 051, 053, 057, 067, 083, 115, 122 and 487	DMU 245	Upper Peninsula and DMUs 005, 010, 015, 024, 028, 040, 043, 045, 051, 053, 057, 067, 083, 115, 122 and 487	
<b>Restricted Combination Deer License</b>				Statewide
<b>Firearm Deer License</b>	Statewide except DMUs 005, 010, 015, 024, 028, 040, 043, 045, 051, 053, 057, 067, 083, 115, 117, 122, 135 and 245	DMUs 117, 135 and 245	DMUs 005, 010, 015, 024, 028, 040, 043, 045, 051, 053, 057, 067, 083, 115, and 122	
<b>Archery Deer License</b>	Statewide except DMUs 005, 010, 015, 024, 028, 040, 043, 045, 051, 053, 057, 067, 083, 115, 117, 122, 135, and 245	DMUs 117, 135 and 245	DMUs 005, 010, 015, 024, 028, 040, 043, 045, 051, 053, 057, 067, 083, 115, and 122	

\* A legal antler point must be at least one inch long.

### Archery Deer Hunting License

It is unlawful to purchase more than one archery deer hunting license. This license entitles residents and nonresidents 10 or older to take one antlered or antlerless deer during the Oct. 1 - Nov. 14 or Dec. 1 - Jan. 1 open bow and arrow deer season. For youth hunting opportunities, see pg. 26. **Exceptions:** See Antler Restriction Regulations above.

### Firearm Deer Hunting License

It is unlawful to purchase more than one firearm deer hunting license. Residents and nonresidents may take a deer with at least one antler three inches or longer during the Nov. 15-30 regular firearm season or during the muzzleloading season. **Exceptions:** A firearm deer license is valid for an antlerless deer in DMU 487. See the 2013 Michigan Antlerless Deer Hunting Digest. Also see Antler Restriction Regulations to the left and Firearm Hunting Rules for Youth Deer Hunters on pg. 26.

### Combination Deer Hunting License

Residents and nonresidents are entitled to purchase only one license with two kill tags (regular and restricted) for use during the firearm, muzzleloading and archery seasons. These tags are not valid for the early/late antlerless firearm seasons. A hunter can use both kill tags in the firearm seasons, both in the archery season or one in each season.

The regular combination kill tag can be used in DMU 487 and all archery seasons to tag either an antlered or antlerless deer. The regular combination kill tag can be used in the firearm seasons to tag a legal (three inches or longer antler) antlered deer except in those areas with antler restrictions as noted in the Antler Restriction Regulations section.

The restricted combination kill tag can be used in DMU 487 and all archery seasons to tag an antlerless deer, or it can be used to tag an antlered deer during either the archery or firearms seasons if the antlered deer has at least one antler with four or more antler points each one inch or longer. It is unlawful to use this tag on a smaller antlered deer regardless of the season or area in which it was taken.

Combination kill tags cannot be used to tag an antlerless deer during the firearm or muzzleloading seasons, except within DMU 487 and during the Liberty and Independence hunts. See the 2013 Michigan Antlerless Deer Hunting Digest.

**Exception:** See Tagging Option for Antlerless Deer Hunters on pg. 37.

### Antlerless Deer Hunting License

This license entitles residents and nonresidents age 10 and older to take an antlerless deer or a deer with antlers less than three inches in length within the DMU specified on the license. Hunters may apply for a private-land OR public-land antlerless deer license from Jul. 15 - Aug. 15. An application is recommended for public-land antlerless deer hunting or private-land hunting in DMUs where license availability is relatively limited. A public-land antlerless deer license is required to hunt antlerless deer on Commercial Forest land. In some DMUs, private-land antlerless deer licenses are only available over the counter beginning Sept. 10. For youth hunting opportunities, see pg. 26 and for additional details on antlerless deer hunting, see the 2013 Michigan Antlerless Deer Hunting Digest.

**Hunters must have landowner permission before hunting on private land. The telephone number of the private landowner is required to acquire a private-land antlerless deer license.**

### Junior Antlerless Deer Hunting License

See pg. 26.

# INFERNO CROSSBOWS

Quality that speaks for itself

OPEN ONLINE SHOPPING CART  
AVAILABLE : [www.arrow-precision.com](http://www.arrow-precision.com)

MSRP \$649.99

NEW FOR 2013



375+ FPS - 165# DRAW

MSRP \$579.99

NEW FOR 2013



345+ FPS - 225# DRAW

MSRP \$419.99

NEW FOR 2013



345 FPS - 150# DRAW

MSRP \$369.99



310+ FPS 185# DRAW

MSRP \$299.99



285+ FPS 150# DRAW

MSRP \$219.99



235+ FPS 175# DRAW

All performance specifications are intended for guidance only.



**Arrow Precision, LLC**  
1619W. Washington Street  
Allentown, PA 18102  
Tel: 610 437-7138 Fax: 610 437-7139  
Email: [sales@arrow-precision.com](mailto:sales@arrow-precision.com)  
[www.arrow-precision.com](http://www.arrow-precision.com)

GET FIRED UP!...



Proud Member of the Michigan Crossbow Federation

Online web retailers:



Interested in becoming an Arrow Precision Dealer?  
Contact Great Lakes Tackle / Sportsman's Supply, and Kinsey's.

Paid Advertisement



©2013 Cabela's, Inc.

## DEER HUNTERS

Travis "T-Bone" Turner is a proud National Spokesperson for WTU

T-Bone says,  
"The time to get involved is now!"

[www.whitetailsunlimited.com](http://www.whitetailsunlimited.com)



We're looking for a few dedicated people to **join our team** and help carry on the hunting tradition. Minimal involvement on your part with a maximum return for projects. For information on starting a Whitetails Unlimited Chapter in Michigan, call Jim Kurdziel at (231) 578-5667, or Jason Maraskine at (989) 859-9489.

# TRUST US. WE'VE BEEN THERE.

Is the outdoor adventure of a lifetime or a weekend getaway in your plans? Cabela's experienced outfitters are ready to help you find everything you'll need for success. When those same outfitters aren't hard at work, they're out there in all the places and conditions you hunt, fish and camp in. So when it comes time to get outside, trust experience, trust Cabela's.

Shop online at [cabelas.com](http://cabelas.com) or visit us in Michigan at:

**Grandville**  
616.682.6700

**Saginaw**  
989.321.5700

**Dundee**  
734.529.4700

*Cabela's*

### Deer Management Assistance (DMA) Permits

DMA permits may be used to take antlerless deer only. Deer taken with DMA permits do not count against a hunter's regular bag limit. DMA permits are not stand-alone licenses. You must purchase an appropriate deer license for the season in which you are hunting.

### Deer Cooperator Patches

Cooperator patches are used as an incentive for successful hunters to bring their deer to DNR offices and other check stations. A deer head (antlers must still be attached on bucks) or entire carcass must be presented to receive a patch. Visit [www.michigan.gov/deer](http://www.michigan.gov/deer) for the final list of 2013 deer check stations. Hunters are urged to call ahead to confirm hours and days of operation. The last day for deer check is Jan. 10, 2014.

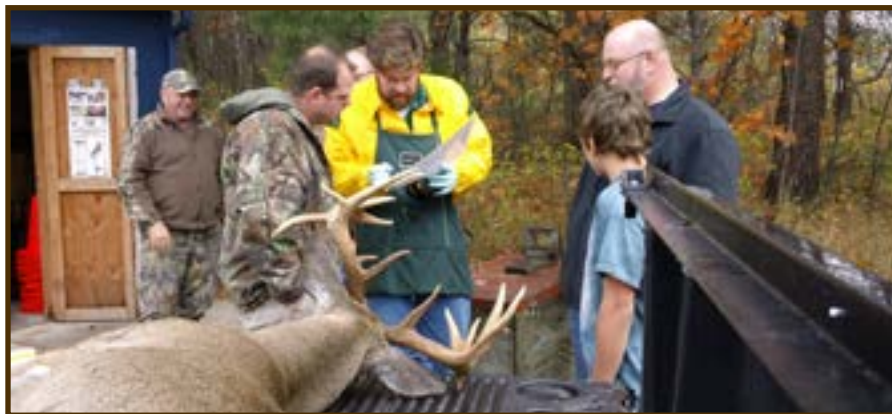

## Deer Management Units

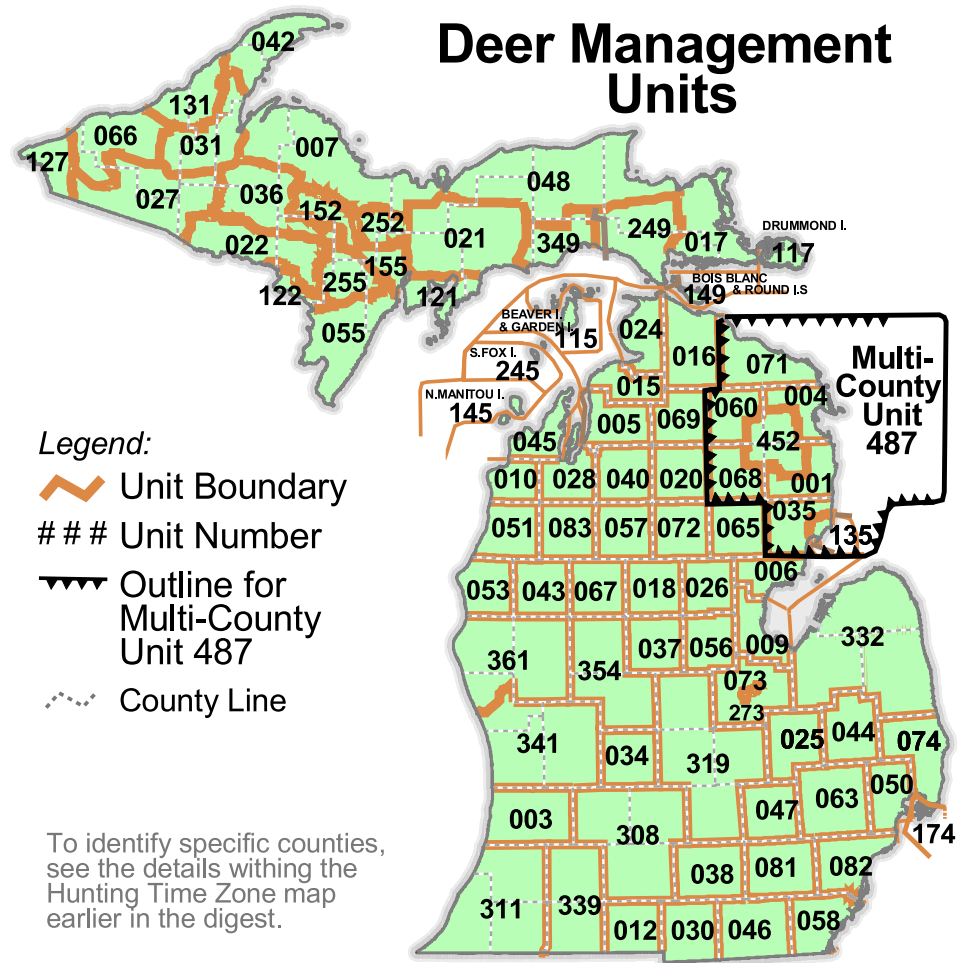

### Tagging Option for Antlerless Deer Hunters

Antlerless deer hunters with a valid unused license for an antlered deer and an unused antlerless license for the DMU in which they are hunting, may tag a male antlerless deer with the antlered deer license kill tag. Both licenses must be in the hunter's possession at the time of harvest. All deer must be immediately tagged.

## Special Deer Hunts

### Fort Custer Training Center

The training center is sponsoring a Freedom Hunt Oct. 18-20, 2013 for hunters eligible to participate in the special deer hunt for persons with disabilities (see pg. 30). Applications can be found at [www.fortcusterhunt.org](http://www.fortcusterhunt.org) or contact Jonathan Edgerly at [Jonathan.w.edgerly.nfg@mail.mil](mailto:Jonathan.w.edgerly.nfg@mail.mil) or by phone at 269-731-6570. The application deadline is Oct. 1, 2013.

### Hoffmaster State Park

This park will not hold a special deer hunt for the 2013 season. For information contact 231-798-3711.

### North Manitou Island Hunts (DMU 145)

Deer hunt licenses are available for archery from Oct. 1-26, 2013, muzzleloading and regular firearm from Oct. 27 - Nov. 13, 2013. There is a \$25 application fee. For information, contact the Park Headquarters, Sleeping Bear Dunes National Lakeshore, 9922 Front Street, Empire, MI 49630; 231-326-5134, or at [www.nps.gov/slbe](http://www.nps.gov/slbe).

### Shiawassee National Wildlife Refuge (SNWR) Deer Hunting

Contact the SNWR (6975 Mower Rd., Saginaw, MI 48601) at 989-777-5930.

### Shiawassee River State Game Area Deer Hunting

Contact the DNR Field Office (225 E. Spruce Street, St. Charles, MI 48655) at 989-865-6211. The deadline for application is Aug. 14, 2013.

### South Fox Island Deer Hunting (DMU 245)

Deer hunting permits are available for South Fox Island during archery season from Oct. 1-28 and/or firearm season from Oct. 29 - Nov. 26. Contact: DNR Customer Service Center, 8015 Mackinaw Trail, Cadillac, MI 49601; 231-775-9727.

## Deer Carcass Disposal

Dumping of deer carcasses or other wild animals is illegal, can spread disease, and may result in a ticket. Hunters who process their deer should properly dispose of all parts. The hide, brain, spinal cord, eyes, spleen, tonsils, bones and head should be disposed of in an approved landfill.

### Be Aware

Growers are using public lands to grow illegal marijuana. If you come upon a marijuana grow site, back out and call 1-800-235-HEMP (4367).

## Small Game License

A small game license entitles you to hunt rabbit, hare, squirrel (fox and gray), pheasant, ruffed grouse, sharp-tailed grouse, woodcock (HIP endorsement required, see pg. 41), quail, crow, coyote (applies to Michigan residents only) and waterfowl (with a federal waterfowl stamp and Michigan waterfowl hunting license, if age 16 or older) during the open season. Opossum, porcupine, weasel, red squirrel, skunk, ground squirrel and woodchuck also may be taken year-round with a valid hunting license. No license is required for a resident, resident's spouse or resident's children to hunt small game on the enclosed farmlands where they live, except a federal waterfowl stamp and state waterfowl license are required to hunt waterfowl.

## Quail

Quail can be hunted only in Branch, Calhoun, Clinton, Eaton, Genesee, Gratiot, Hillsdale, Huron, Ingham, Ionia, Jackson, Kent, Lapeer, Lenawee, Livingston, Macomb, Monroe, Montcalm, Oakland, Saginaw, St. Clair, St. Joseph, Sanilac, Shiawassee, Tuscola, Washtenaw and Wayne counties. All other counties are closed to quail hunting. Please see the State Parks and Recreation Areas section for the restrictions at Highland and Ionia Recreation Area on pg. 15.

## Sharp-tailed Grouse

The area open to sharp-tailed grouse hunting Oct. 10-31 in Zone 1 (U.P.) includes the green shaded area shown below. Visit the DNR website for the complete detailed definition of this boundary. A free sharp-tailed grouse stamp, available from all license agents or online at [www.michigan.gov/hunting](http://www.michigan.gov/hunting), is required in addition to a valid small game hunting license for those hunting sharp-tailed grouse.

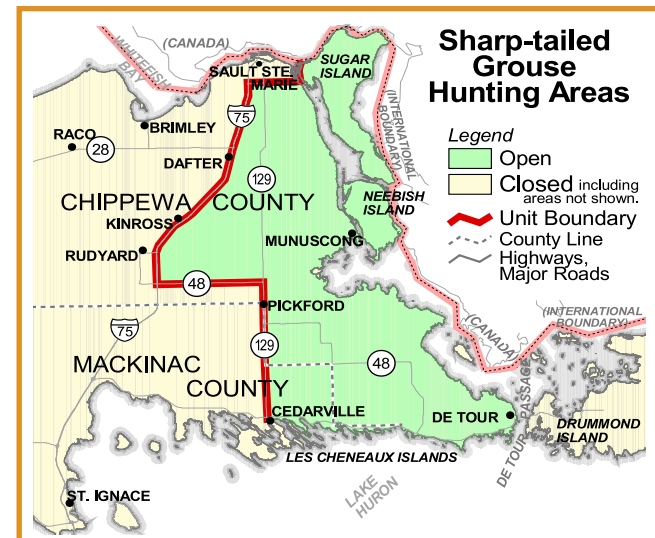

## Game Bird Hunting Preserves

All those hunting on a licensed game bird hunting preserve must have a current Michigan small game license or game bird hunting preserve license.

## Pheasant

The area open to pheasant hunting Oct. 10-31 in Zone 1 (U.P.) includes all of Menominee County and portions of Delta, Dickinson, Iron and Marquette counties. See the DNR website at [www.michigan.gov/dnr/laws](http://www.michigan.gov/dnr/laws) for the complete detailed definition of this and other unit boundaries.

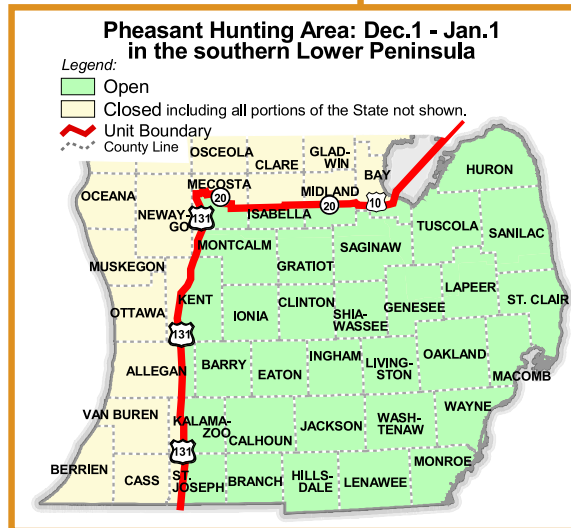
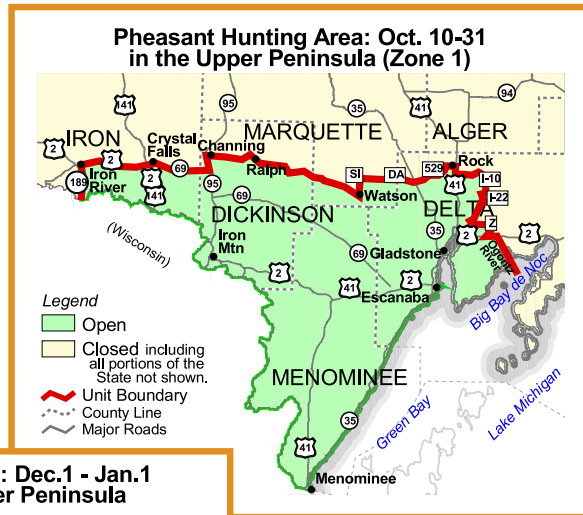

In addition to the October and November pheasant hunting seasons, the green shaded area, shown to the left, is open to pheasant hunting Dec. 1 - Jan. 1 for the taking of male pheasants.



## Waterfowl

### Michigan Waterfowl Hunting License

In addition to a small game license, all waterfowl hunters age 16 and older are required to purchase a Michigan waterfowl license. For information on waterfowl seasons, bag limits and other regulations, see the 2013-2014 Michigan Waterfowl Hunting Digest (available Sept. 15) and the 2013 Waterfowl Reserved Hunt brochure (available Aug. 1).

### Federal Migratory Bird Hunting Stamp

This stamp is required for all waterfowl hunters 16 and older, including people hunting on their own enclosed farmland. Federal waterfowl stamps are not required for hunting woodcock, rails and snipe. The federal stamp must be signed across its face with your name in ink. The stamps are available at post offices and some Michigan license agents or go to [www.fws.gov/duckstamps](http://www.fws.gov/duckstamps).

## Migratory Game Birds

### Harvest Information Program (HIP)

If you are planning to hunt migratory birds (ducks, geese, woodcock, snipe, rails, etc.) in Michigan, you must have a Harvest Information Program endorsement printed on your small game license. The HIP endorsement, which consists of the statement: "Migratory Bird Hunter—YES," is printed on your small game license when you answer the HIP survey questions. There is no cost for this endorsement. If the agent fails to ask you the HIP question, you can do any of the following to receive the endorsement:

- Ask the agent to reissue the license.
- Visit the DNR e-license website at [www.mdnr-elicense.com](http://www.mdnr-elicense.com) and go to the small game category, then choose the free "HIP Survey Migratory Bird" item.
- Visit any DNR Customer Service Center, (see back of digest).
- If you purchase a waterfowl hunting license, the HIP endorsement is automatically included. It must be added by the agent if you are purchasing a small game license and plan to hunt woodcock. Those who hunt migratory birds without this endorsement can be fined.

## Woodcock and Waterfowl Leg-band Reporting

Every hunter can promote sound woodcock and waterfowl management by promptly reporting all banded birds harvested, including date and location taken. This information is used to determine annual survival and migration routes. To report bands go online to [www.reportband.gov](http://www.reportband.gov), call 800-327-BAND, or write: USGS Patuxent Wildlife Research Center, Bird Banding Laboratory, 12100 Beech Forest Road, Laurel, MD 20708-4037.

## Early September Canada Goose Hunting

**Dates:** See map below.

**Daily Limit:** 5 Canada geese daily.

**Possession Limit:** 15 Canada geese.

**Hunting Hours:** One-half hour before sunrise to sunset.

**Open Hunt Areas:** Statewide, excluding some wildlife areas and portions of some state parks and recreation areas. See map along with the following:

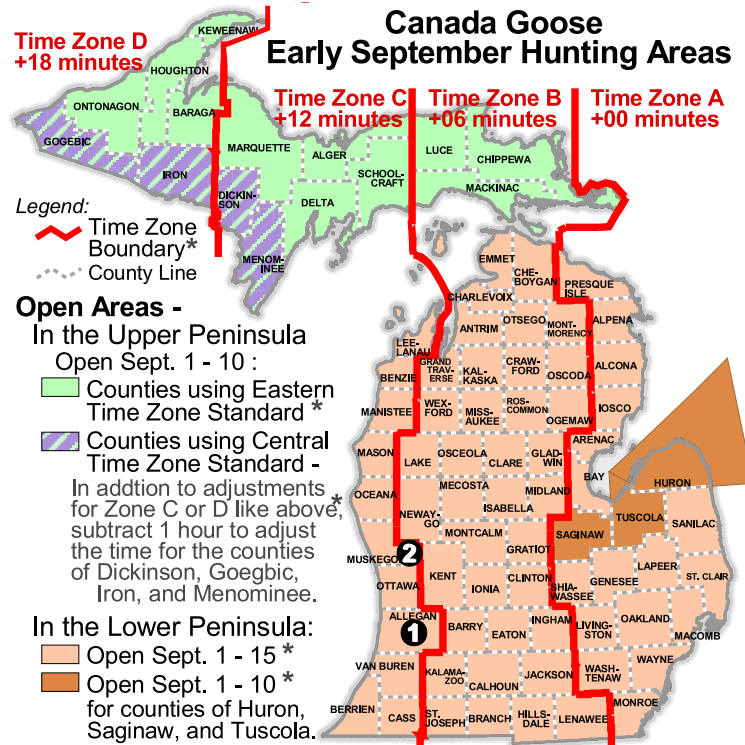

Zone A Hunting Hours															
Sept.	1	2	3	4	5	6	7	8	9	10	11	12	13	14	15
A.M.	6:28	6:29	6:30	6:31	6:32	6:33	6:34	6:35	6:36	6:37	6:38	6:39	6:40	6:41	6:43
P.M.	8:06	8:04	8:03	8:01	7:59	7:57	7:56	7:54	7:52	7:50	7:49	7:47	7:45	7:43	7:42

State Parks (S.P.), Scenic Sites (S.S.), Recreation Areas (R.A.) and Wildlife Research Areas (W.R.A.)

**(1) All or portions of the following areas are open Sept. 1-10:**

- Port Crescent S.P.
- Sleeper S.P.

**(2) Portions of the following areas are open Sept. 1-15:**

- Bald Mountain R.A.
- Bay City R.A.
- Brighton R.A.
- Grand Mere S.P.
- Highland R.A.
- Holly R.A.
- Ionia R.A.
- Lake Hudson R.A.
- Mitchell S.P.
- Negwegon S.P.
- Ortonville R.A.
- Pinckney R.A.
- Pontiac Lake R.A.
- Proud Lake R.A.
- Rose Lake W.R.A.
- Sleepy Hollow S.P.
- Thompson's Harbor S.P.
- Waterloo R.A.
- Wetzel R.A.

**(3) All or portions of the following areas are open Sept. 3-10:**

- Brimley S.P.
- Craig Lake S.P.
- Fayette S.P.
- Indian Lake S.P.
- Falls S.S.
- Laughing Whitefish
- McLain S.P.
- Palms Book S.P.
- Porcupine Mountains S.P.
- Tahquamenon Falls S.P.
- Van Riper S.P.
- Wagner Falls S.S.

**(4) All or portions of the following areas are open Sept. 3-15:**

- Cheboygan S.P.
- Ludington S.P.
- Sterling S.P.
- Fisherman's Island S.P.
- Metamora-Hadley R.A.
- Sturgeon Point S.P.
- Fort Custer R.A.
- Rifle River R.A.
- Wilderness S.P.
- Hoeft S.P.
- Seven Lakes S.P.
- Yankee Springs R.A.
- Island Lake R.A.
- Silver Lake S.P.
- Leelanau S.P.
- South Higgins Lake S.P.

**Contact your local DNR Parks and Recreation or Wildlife office for information.**

Help Build Tomorrow's...

## Michigan Waterfowl Legacy

A ten-year cooperative partnership to restore, conserve and celebrate Michigan's waterfowl, wetlands, and waterfowl hunting community.

[www.michigan.gov/mwl](http://www.michigan.gov/mwl)



**MICHIGAN WATERFOWL LEGACY**  
YESTERDAY, TODAY, AND TOMORROW

### DNR Offers Trapper Education Program

For information on classes currently offered in your area, please visit the DNR website at [www.michigan.gov/trapping](http://www.michigan.gov/trapping) and click on Michigan Trapper Education.

### Fur Harvester License

All those who hunt and trap furbearing animals, including those who trap or hunt on their own enclosed farmland or private property, must have a valid fur harvester license. This license allows you to hunt fox, bobcat, coyote or raccoon, and trap badger, bobcat, fisher, marten, fox, coyote, weasel, mink, raccoon, muskrat, beaver, otter, skunk or opossum. **Exception:** See footnotes 1, 3 and 6 in table on pg. 10.

Those 10 years of age and older must possess a valid fur harvester license. A junior resident fur harvester trap only license is available to youth 10 to 16 years old without hunter safety training. Youth under 10 years old may trap furbearers as licensed through the Mentored Youth Hunting Program (see pg. 25).

### Nonresident Fur Harvester License

Nonresidents may hunt and trap furbearing animals only from Nov. 15 through the regular season closing dates (except for beaver and otter; see map on pg. 51 for nonresident season dates). A nonresident cannot purchase a license before Nov. 15. Residents of Wisconsin, Minnesota, North Dakota, South Dakota and the province of Ontario cannot purchase a Michigan nonresident fur harvester license.

Immediately after taking a bobcat, otter, fisher or marten, you must validate your kill tag and fasten it in such a manner that the tag remains securely attached to the animal. For details on furbearer kill tags and proper placement, see below. Make sure the kill tag is completely legible and visible for inspection. It is unlawful to tag an animal you did not legally kill.

### Furbearer Kill Tags

A person who intends to harvest bobcat, otter, fisher or marten must request and will be issued free kill tags for these species. These tags are available Sept. 15 through the last day of the hunting and trapping season for that furbearer. Kill tags will be available from license agents or by contacting any DNR Customer Service Center. A person who kills a bobcat, otter, fisher or marten shall immediately validate the tag and attach the tag to the hide from the upper jaw to the eye socket or through the lower jaw. Those under 8 years of age may not obtain a kill tag for bobcat, otter, fisher or marten. The kill tag must be replaced by an official DNR seal for registration. See Furbearer Registration, pg. 45. Because of the change in stock for the new license year beginning, Mar. 1, 2014, otter tags for 2013-2014 will be available only from Sept. 15, 2013 to Mar. 1, 2014. After Mar. 1, individuals who have not obtained their 2013-2014 otter kill tags should contact a DNR Customer Service Center to request tags. Kill tags may also be obtained from a license agent with a valid fur harvester license after Mar. 1.

### Furbearer Registration

A person taking a bobcat, fisher, marten, otter or incidental catches must present the animal at a DNR office for registration. See the table below for registration dates. Fur takers must register their own take. It is unlawful to register the take of another person. Customer Service Centers will be, and other DNR offices may be, open during normal business hours. Hunters and trappers are strongly encouraged to call ahead to determine availability of DNR personnel or to make arrangements to register animals outside normal working hours on an appointment basis. The DNR will attach an official seal to the pelt of each animal. This seal replaces the furbearer kill tag that was attached to the hide immediately after harvest (see Furbearer Kill Tags section on pg. 44). The location of take, date of harvest and manner of harvest will be recorded when the animal is sealed. The skull will also be collected to determine the sex, age and physical condition of the specimen. Skulls will be retained and will not be returned. Requiring skulls from all species ensures tooth samples are undamaged for aging and adequate material is available for DNA analysis. In addition, the DNR is developing new population estimation techniques for furbearer species. These new techniques require precise sex and age information, which will be obtained from skulls. Ages for bobcat, fisher, and marten can be found at [www.michigan.gov/dnr/lab](http://www.michigan.gov/dnr/lab).

Seals may be removed by a licensed taxidermist upon acceptance and recording of the specimen. Otherwise, seals shall not be removed until the pelt is processed or tanned, nor shall a person possess or transport a raw, unsealed hide after the required registration date for each animal. A person may not buy or sell a bobcat, fisher, marten or otter pelt without a DNR seal unless the pelt has been processed or tanned. Animals should be skinned prior to registration. The pelt and carcass or skull should be brought in to a local DNR office for registration.

Species	What is required for registration?	What will be kept from each specimen?	When must I register?
<b>Bobcat</b>	The skull and pelt for sealing.	The skull.	Trapping Season <ul style="list-style-type: none"> <li>Units A and B, on or before Feb. 11, 2014</li> <li>Units C,D,E &amp; F on or before Dec. 30, 2013</li> </ul> Hunting Season <ul style="list-style-type: none"> <li>Units A,B, and C, on or before Mar. 11, 2014</li> <li>Unit D, on or before Feb. 11, 2014</li> <li>Units E and F, on or before Jan. 21, 2014</li> </ul>
<b>Fisher</b>	The skull and pelt for sealing.	The skull.	on or before Dec. 18, 2013
<b>Marten</b>	The skull and pelt for sealing	The skull.	on or before Dec. 18, 2013
<b>Otter</b>	The skull and pelt for sealing.	The skull.	<ul style="list-style-type: none"> <li>Units A &amp; B on or before Apr. 23, 2014</li> <li>On designated trout streams in Unit A on or before May 5, 2014</li> <li>Unit C, on or before Apr. 10, 2014</li> </ul>
<b>Incidental catches*</b>	The entire carcass and pelt.	The entire carcass and pelt.	See pg. 50 for details

\*Includes wolves, lynx and over-harvest of badger, bobcat, fisher, marten and otter

## Fur Harvester Rules

- Trappers are legally required to check restraining-type traps and cable restraints at least once each day in Zones 2 and 3 and at least once within each 48-hour period in Zone 1. It is highly recommended that trappers in Zone 1 check restraining-type traps and cable restraints daily.
- Centerfire or rimfire rifles may be used Dec. 1 - Nov. 9 in the Shotgun Zone during the seasons for all species open to take with firearm, except rifles may NOT be used for deer, turkeys and migratory game birds. See pg. 54-55 for Nighttime Raccoon and Predator Hunting restrictions.
- From Nov. 15-30, a .22 caliber or smaller rimfire rifle or handgun may be used to kill a raccoon while hunting raccoons with dogs between the hours of 7 p.m. and 6 a.m.
- From Nov. 15-30, a licensed fur trapper may carry and use a .22 caliber or smaller rimfire to kill legally trapped coyote, fox, raccoon, bobcat and badger, firearm may only be loaded at the point of kill.

## Don't Forget

### It is illegal to:

- Use any kind of a trap other than a foothold, body-gripping or conibear-type trap unless specifically otherwise provided.
- Use a foothold trap with a jaw spread exceeding a number 2 foothold trap when taking mink or muskrat.
- Use snares or live traps. Exceptions: See Beaver and Otter Trapping Regulations on pg. 51, Live Traps on pg. 50, and Winter Fox and Coyote Non-lethal Cable Restraints on pg. 53.
- Use a trap with teeth or serrations.
- Use or have in possession or transport in an area frequented by wild animals a catching device of any kind without permanent etching or a metal tag bearing the user's name and address or Michigan driver license number. **Exception:** See Beaver and Otter Trapping Regulations on pg. 51.
- Set a steel trap within 50 feet of any water in Zone 1 before Oct. 25, before Nov. 1 in Zone 2 or before Nov. 10 in Zone 3, unless a duffer-type, egg-type, or similarly designed foothold trap for raccoon is used, or a body-gripping or conibear trap that is placed four feet or more above the ground. See pg. 11 for the hunting and trapping zone map.
- Molest or disturb or set a trap in the internal compartment of any structure such as a lodge, hut, push-up, house, hole, nest, burrow or den of a badger, beaver, mink, muskrat or raccoon, whether occupied or not, or molest or destroy a beaver dam, except under a DNR Wildlife Damage Investigation and Control Permit.
- Set a trap on a beaver dam or lodge unless the trap is submerged below the water.

- Transport or possess live game taken from the wild, except under a rehabilitation permit, or as specified in a DNR Wildlife Damage and Nuisance Control Permit.
- Stake, put out or set a catching device at any time before the day the open season begins.
- Use a multiple catch or colony trap except for taking muskrats, provided the trap is completely submerged. Colony traps must be constructed of steel and be no larger than eight inches high, eight inches wide and 36 inches deep. (Nuisance control operators MAY use colony traps for muskrats and other species.)
- Bring a live raccoon or skunk into Michigan.
- Shoot a muskrat, beaver, otter, mink, fisher or marten, except under DNR permit. Coyote, fox, raccoon, bobcat and badger may be killed in traps by fur takers using .22 caliber or smaller rimfire firearms, except for junior fur harvesters with trap-only licenses.
- Use a .22 caliber or smaller rimfire firearm to dispatch coyote, fox, raccoon, bobcat and badger from Nov. 15-30 in the Shotgun Zone unless the firearm is loaded at the point of kill only.
- Trap any species within Sleeping Bear Dunes National Lakeshore and Pictured Rocks National Lakeshore.

## Deciding What Trap to Use

The following regulations were developed to help improve the selectivity of dryland body-gripping traps in an effort to reduce the take of non-target animals. Although the set regulations on the following pages are required only on public land, these sets also may be useful to private-land trappers. Find information on safely removing animals from traps at [www.michigan.gov/trapping](http://www.michigan.gov/trapping) under Related Resources.





### Dryland and Surface Ice Public Land Body-Gripping Trap Regulations:

Body-gripping traps less than 5.5 inches inside the jaw hinges may be set without restrictions if used according to other regulations. All legal body-gripping traps of any size may be used if they are 4 or more feet off the ground without set restriction.

Body-gripping traps set on dryland or on ice on public lands without the use of bait, lure or attractant must be no greater than 6.5 inches inside the jaw hinges (160s) and only may be set such that no part of the body-gripping surface is more than eight inches above the ground (see figure below).

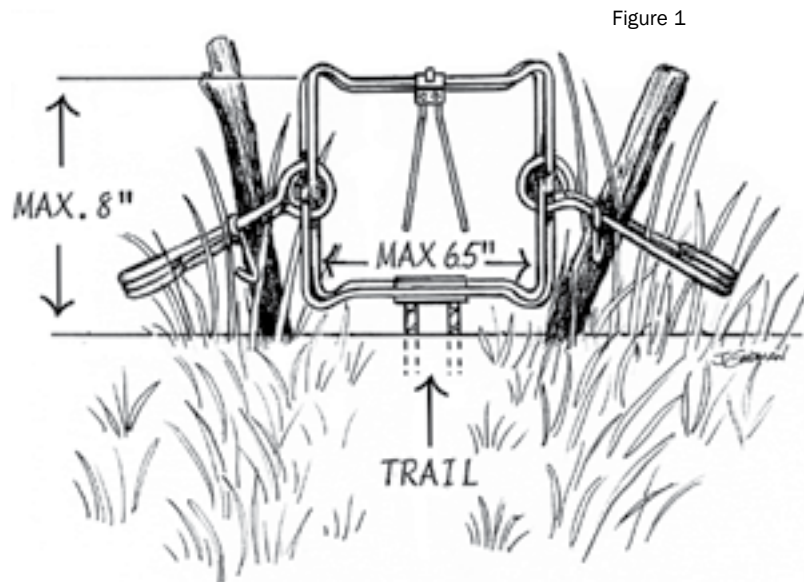

Figure 1

Body-gripping traps 5.5 inches to 7.5 inches inside the jaw hinges (160s and 220s) set on dryland or on ice with the use of bait, lure or other attractants may be used only in the following manner:

**In a container of the following design:**

- opening height six inches or less
- eight-inch minimum spring trap placement slots
- trap trigger recessed minimum of six inches

Figure 2

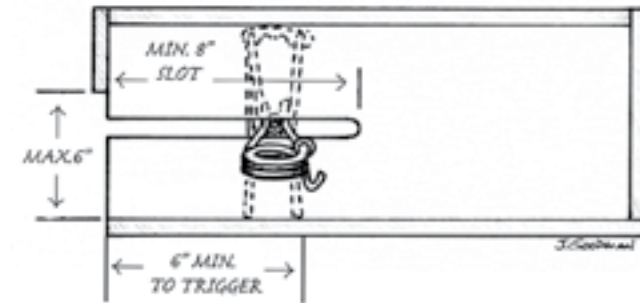
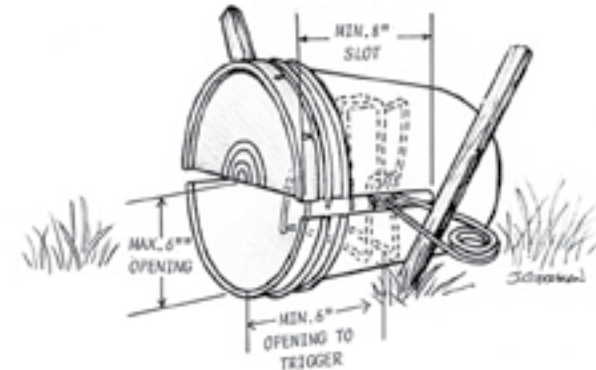

Figure 3



**In a container of the following design:**

- only one entrance facing the ground
- container set so entrance is no more than six inches from ground.
- trap trigger recessed minimum of four inches.

Figure 4

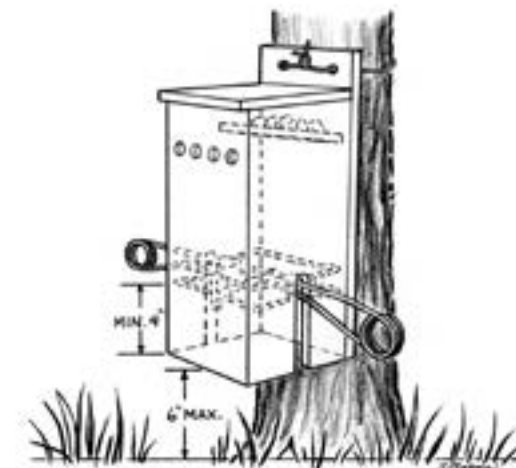

## Dryland and Surface Ice Private Land Body-Gripping Trap Regulations

It is unlawful to set a body-gripping or conibear-type trap larger than 7.5 inches in width (as measured inside the jaw hinges) on drylands that are privately owned, or over frozen submerged privately owned bottomlands unless the trap is 4 or more feet above dry ground or the frozen surface of ice. See pgs. 48-49 for regulations for body-gripping traps on publicly owned lands.

## Use of Bait when Trapping

Trappers may use game animals and game birds or their parts, lawfully taken and possessed as bait, only during the open season for those animals or birds. Other game, protected animals, birds or deer parts from taxidermy operations may not be used as bait. Your bait should be placed where it is not visible by hawks, owls and eagles.

## Use of Live Traps

As a substitute for foothold traps, trappers may use live traps capable of taking only one animal at a time within 450 feet of an occupied dwelling and associated buildings during the legal time for trapping the target animal. Live traps must be checked daily. Any animal captured in a live trap must be immediately killed or released; it is illegal to take these game animals or protected animals live from the wild. It also is illegal to hold these animals in captivity.

## What To Do When You Have an Incidental Catch

Trappers occasionally trap non-targeted species. It is unlawful to possess animals out of season or those which are non-game protected species. The following procedure is required for non-game protected species and those furbearers with a bag limit (bobcat, badger, fisher, marten, and otter) to help the DNR collect and utilize the biological data available through carcass examination and ensure that pelts are put to good use. Trappers must:

- Immediately release live protected animals from the trap.
- If the animal is dead or dies in the attempt to release it, attach a Michigan incidental seal to the animal before removing it from the trap. Then transport the carcass in an open manner to the nearest DNR office. The carcass must be surrendered.
- Michigan incidental seals are available from DNR offices. **All incidental seals remain the property of the DNR and must be returned by May 1 each year.**

## Shipping Hides and Furs

All out-of-state shipments of raw hides or furs must be plainly marked on the outside of the package as to the contents. To export bobcat, otter or wolf hides from the U.S. you need federal approval. For details, contact the U.S. Fish and Wildlife Service at 800-358-2104 or e-mailing [managementauthority@fws.gov](mailto:managementauthority@fws.gov).

## Beaver and Otter Trapping Regulations

### Statewide Season Limits

**Beaver:** No limit

**Otter:** Three per person. Only two may be taken from Unit B, and only one from Unit C. Also see Note 3 below.

In addition to the general fur harvester rules on pg. 46, the following regulations apply to beaver and otter trapping:

- Only foothold, body-gripping or conibear-type traps may be used for taking beaver and otter. Traps with teeth are illegal. **Exception:** See below for use of snares to take beaver.
- A catching device of any type must have a permanent etching or metal tag bearing the user's name and address or Michigan driver license number. If one or more snares are attached to a pole, both the snare and the uppermost end of the pole need a metal tag.
- Snares may be used for taking beaver in water or under ice, statewide. Snares must be made of 1/16-inch or larger cable. Snares not under ice must have a loop which is at least half submerged and be set in a fashion to hold the beaver completely submerged. Snares shall be removed and made inoperative within 24 hours after the close of the beaver season.
- Up to 10 muskrat pelts may be legally taken in beaver or otter sets.

### Notes:

1. The beaver and otter trapping season in Unit A extends through Apr. 30 on designated trout streams only. For a list of these streams in the Upper Peninsula, see Fisheries Order FO-210.08 at [www.michigan.gov/dnr/laws](http://www.michigan.gov/dnr/laws).
2. The Gladwin Field Dog Trial Area is closed to trapping except for beaver and otter trapping, which is permitted from Nov. 15, 2013 through Mar. 15, 2014.
3. Fur harvesters must purchase a new license after Mar. 31. The season limit for otter does not change with the purchase of a new license. Otter taken between Apr. 1-30, 2014 count against the 2013-2014 otter season bag limit. A free otter kill tag is required. See Furbearer Kill Tags on pg. 44.

continued on next page

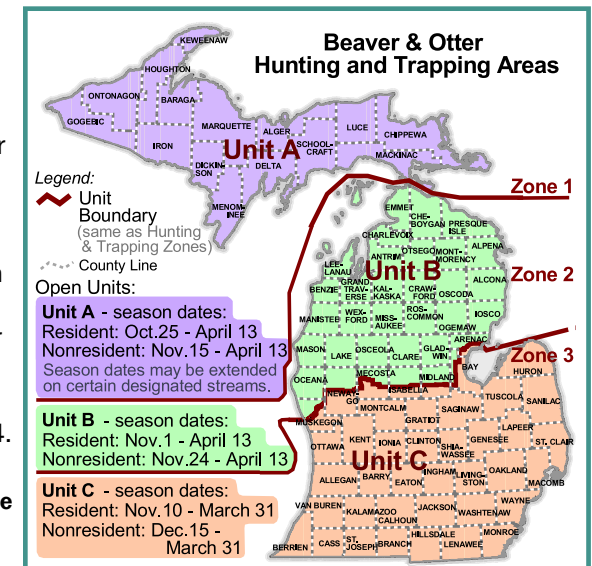

continued

**Beaver and otter trapping are closed in the following areas:**

**Alger:** Pictured Rocks National Lakeshore, **Benzie:** Sleeping Bear Dunes National Lakeshore, **Leelanau:** Sleeping Bear Dunes National Lakeshore, **Schoolcraft:** Seney National Wildlife Refuge, closed to otter trapping. Contact the refuge on possible beaver trapping. **Also see Special Public Land Trapping Areas on pgs. 54-55.**

**Bobcat Units and Bag Limits**

Unit A includes all of the Upper Peninsula, except Drummond Island. Unit B is Drummond Island. Unit C includes Alcona, Alpena, Antrim, Charlevoix, Cheboygan, Emmet, Montmorency, Oscoda, Otsego and Presque Isle counties. Unit D includes Clare, Crawford, Gladwin, Iosco, Kalkaska, Missaukee, Ogemaw, Osceola, Roscommon and Wexford counties, and Arenac County north of M-61 and west of I-75. Unit E includes all of Benzie, Leelanau, Grand Traverse, Lake, Manistee and Mason Counties. Unit F includes all of Isabella, Mecosta, Midland, Newaygo, and Oceana Counties, and those portions of Arenac and Bay counties that are in zone 2, except the portion of Arenac County that is in Unit D.

**Bag Limits:** The season bag limit for bobcat is two per person; only one bobcat may be taken in Units C, D, E and F combined; and only one bobcat may be taken from Unit B. A free kill tag is required (see pg. 44).

**Bobcat Hunting with Dogs:** A fur harvester license is required by any individual in

possession of a firearm, crossbow or bow and arrow who accompanies a licensed bobcat hunter during the hunt. This license also is required by the owner of any dog chasing or locating bobcat on a hunt.

**Fisher and Marten Open Area and Bag Limit**

The fisher and marten open area includes all of Zone 1 (Upper Peninsula), except Drummond Island.

**Bag Limit:** The season limit is one marten per person OR one fisher per person.

**Note:** A free kill tag is required for fisher and marten. See pg. 44.

**Winter Fox and Coyote Non-lethal Cable Restraints**

**Non-lethal cable restraints** may be used from Jan. 1 - Mar. 1 to take fox and coyotes, provided:

- Cable restraints are not placed on publicly owned land or Commercial Forest lands ( see pg. 14).
- All cable restraints in possession or carried afield must have a metallic identification tag affixed with the owner’s or user’s name and address or Michigan driver license number.
- Steel cable 1/16-inch or larger is used.
- The cable restraint loop does not exceed 15 inches in diameter.
- The top of the loop is not placed more than 24 inches above the ground. In snow, 24 inches is measured from the compacted snow in a trapper’s footprint established by the full body weight of the trapper.
- Cable restraints are equipped with a relaxing lock. A relaxing lock is defined as a lock that allows the loop to loosen slightly to reduce the possibility of strangulation. Cable restraints also must be equipped with a stop to prevent the loop from closing to a diameter less than 4¼ inches. Regulations on loop size and relaxing lock are designed to prevent the accidental loss of domestic animals and other non-target species.
- Cable restraints are equipped with a breakaway locking system with a breaking point not greater than 285 pounds. The breakaway device must be attached to the relaxing lock.
- Cable restraints are affixed to a stake or object sufficient to hold a fox or coyote. It is illegal to use any type of drag.
- Cable restraints are equipped with two swivels, including one swivel at the anchor point.
- Spring poles, counterbalanced weights, springs or other similar devices are not used to close the cable restraint.
- Cable restraints may be up to 60 inches in length, not including a cable anchor extension. The cable anchor extension may be up to 36 inches in length.
- Cable restraints are not attached to a fence or set in a manner that would allow

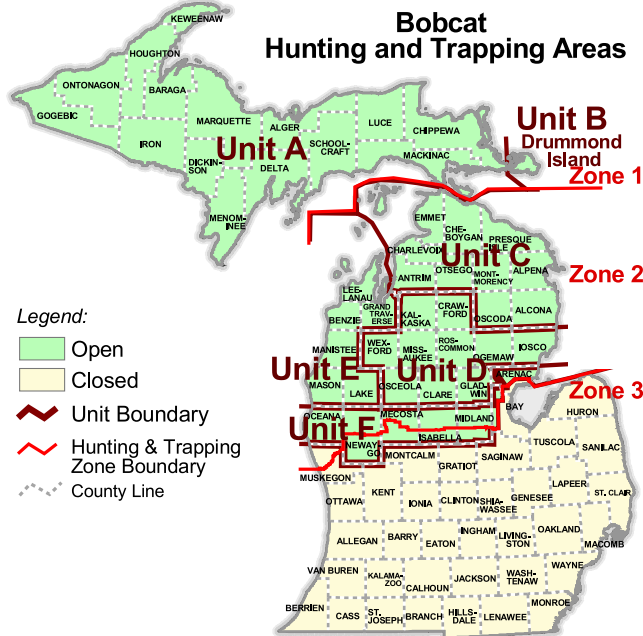

- an animal to become entangled in a fence.
- Cable restraints may be anchored to woody vegetation provided that the stem is free of branches and stubs to a height of five feet above the ground or compacted snow. Branches and stubs must be cut flush with the outer bark of the stem.
- Cable restraints may not be set so that a restrained animal is suspended with two or more feet off the ground.

**Note:** Dogs and other domestic animals caught in cable restraints, body-gripping or conibear-type traps should be reported to the DNR Report All Poaching hotline at 800-292-7800. Find information on safely removing dogs from traps at [www.michigan.gov/trapping](http://www.michigan.gov/trapping) under Related Resources.

### Special Public Land Trapping Areas

A special permit is required to trap in the management areas listed below, and trapping season closure dates may vary. Contact area headquarters for details.

- Muskegon State Game Area. Trapping permits are required for beaver and otter and are available at the game area headquarters.
- Poel Island Waterfowl Refuge, Grand Haven State Game Area. Trapping permits are available at the Muskegon State Game Area headquarters.

- Fish Point State Wildlife Area. Trapping permits are available at the wildlife area headquarters.
- Nayanquing Point and Wigwam Bay State Wildlife Areas. Trapping permits are available at the Nayanquing Point State Wildlife Area headquarters.
- Shiawassee River State Game Area. Trapping permits may be obtained at the St. Charles field office. Trapping permits for the Shiawassee National Wildlife Refuge may be obtained from the refuge manager.
- Tobico Marsh Unit of Bay City Recreation Area. Trapping permits are available at the headquarters.
- Pte. Mouillee State Game Area. Trapping permits are available at the game area headquarters.
- Crow Island State Game Area. Trapping permits are available at the Bay City Operations Service Center.
- Harsens Island, St. Clair Flats Wildlife Area. Trapping permits are available at the wildlife area headquarters.
- State Parks and Recreation Areas. Check with the park headquarters for current trapping regulations and any restrictions prior to trapping.

#### Nighttime Raccoon and Predator Hunting

Species & Season Dates	Lawful Devices	Lawful to take with the aid of dogs at night?	Lawful to take with the aid of a game or predator call at night?	Lawful to use artificial lights? <sup>1</sup>	Lawful to take on private property with owner permission when causing damage?
<b>Raccoon</b> • <b>Hunting Season:</b> Oct. 1 - Jan. 31 <sup>2</sup>	Bow and arrow, crossbow, rimfire firearm .22 caliber or smaller, or shotgun with loads other than buckshot, slug or cut shell. While hunting with dogs from Nov. 15-30 between 7pm - 6am a rimfire firearm .22 caliber or smaller may be used.	Yes	Yes	<ul style="list-style-type: none"> <li>• Yes; when following dogs and at the point of kill.</li> <li>• Yes; with the aid of a game or predator call.</li> </ul>	Yes; year round by lawful hunting or trapping methods
<b>Opossum</b> • <b>Hunting Season:</b> Sept. 15 - Mar. 31 <sup>2</sup>	Bow and arrow, a crossbow, a rimfire firearm .22 caliber or smaller or shotgun with loads other than buckshot, slug or cut shell. Rifles and handguns are prohibited from Nov. 15-30 in the Shotgun Zone.	Yes	Yes; during the open season for fox hunting	<ul style="list-style-type: none"> <li>• Yes; when following dogs and at the point of kill</li> <li>• Yes; with the aid of a game or predator call and during season for fox hunting.</li> </ul>	No
<b>Fox</b> • <b>Hunting Season:</b> Oct. 15 - Mar. 1 <sup>2</sup>	Bow and arrow, a crossbow, a rimfire firearm .22 caliber or smaller or shotgun with loads other than buckshot, slug or cut shell. Rifles and handguns are prohibited from Nov. 15-30 in the Shotgun Zone.	Training only; no harvest	Yes	<ul style="list-style-type: none"> <li>• Yes; with the aid of a game or predator call</li> </ul>	No
<b>Coyote</b> • <b>Hunting Season:</b> Jul. 15 - Apr. 15 <sup>2</sup>	Bow and arrow, a crossbow, a rimfire firearm .22 caliber or smaller or shotgun with loads other than buckshot, slug or cut shell. Rifles and handguns are prohibited from Nov. 15-30 in the Shotgun Zone.	Training only; no harvest	Yes; during the open season for fox hunting	<ul style="list-style-type: none"> <li>• Yes; with the aid of a game or predator call and during the season for fox hunting</li> <li>• Yes; when training dogs</li> </ul>	Yes; year round by lawful hunting or trapping methods

**Note:** A nonresident cannot purchase a fur harvester license before Nov. 15 of each year.  
<sup>1</sup>Only lights similar to the type ordinarily held in the hand or on the person may be used, such as flashlights, portable battery-powered spotlights, and headlamps. The use of natural light, including night-vision optics and scopes is legal. Spotlights powered by vehicle batteries, floodlights, vehicle headlights, and other lights not designed to be carried are illegal.

<sup>2</sup>All hunters using a .22 or smaller caliber rimfire to take a furbearing animal, day or night, from Nov. 10-14, must have a fur harvester license.

## Report Sightings of Diseased Wildlife

In an effort to maintain healthy wildlife populations, the DNR encourages people to report any sightings of sick or dead wildlife to [www.michigan.gov/wildlifedisease](http://www.michigan.gov/wildlifedisease).

## Bovine Tuberculosis

In 2012, bovine tuberculosis (TB) was found in 23 wild white-tailed deer from four counties in Michigan: Alcona, Alpena, Montmorency, and Oscoda; and in one wild elk from Montmorency Co. Statewide 4,716 deer were tested. Since 1995, a total of 732 deer have been found positive from over 200,000 deer sampled in Michigan. For more information on bovine TB in Michigan, visit [www.michigan.gov/bovinetb](http://www.michigan.gov/bovinetb).

The DNR is urging hunters to submit their deer's head for TB testing if it was harvested in the following nineteen counties: Alcona, Alpena, Bay, Cheboygan, Crawford, Genesee, Gratiot, Iosco, Isabella, Midland, Montmorency, Ogemaw, Oscoda, Otsego, Presque Isle, Roscommon, Saginaw, Shiawassee, and Tuscola. Hunters are asked to submit deer carcasses with chest lesions suspicious for TB from anywhere in the state. The list of deer check stations is available on the DNR website at [www.michigan.gov/deer](http://www.michigan.gov/deer). If you see a deer with this type of infection, please contact the DNR so the carcass and viscera, in addition to the head, can be examined. Hunters may check their deer or elk TB lab results at [www.michigan.gov/dnrlab](http://www.michigan.gov/dnrlab).

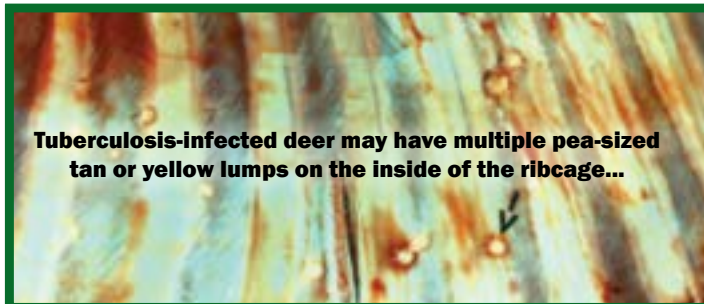

**If you see a deer with this type of infection, please contact the DNR so the carcass and viscera, in addition to the head, can be examined.**

## Epizootic Hemorrhagic Disease

Epizootic hemorrhagic disease (EHD) is an acute, infectious, often fatal disease contracted by wild ruminants but most commonly affecting white-tailed deer. For more information, visit [www.michigan.gov/emergingdiseases](http://www.michigan.gov/emergingdiseases).

## Hunters Importing Deer, Elk or Moose

Harvested free-ranging deer, elk or moose from Colorado, Illinois, Kansas, Maryland, Minnesota, Missouri, Nebraska, New Mexico, New York, North Dakota, South Dakota, Texas, Utah, Virginia, West Virginia, Wisconsin, Wyoming, Alberta, or Saskatchewan have importation restrictions. As these states and provinces have detected Chronic Wasting Disease (CWD) in free-ranging animals, only the following parts of a deer, elk, or moose carcass may be brought into Michigan: deboned meat, antlers, antlers attached to a skull cap cleaned of all brain and muscle tissue, hides, upper canine teeth, or a finished taxidermy mount. If you are notified by another state or province that a deer, elk or moose you brought into Michigan tested positive for CWD, you must contact the DNR Wildlife Disease Lab within two business days (8 a.m. to 5 p.m.) at 517-336-5030 and provide details. Any changes to importation regulations will be posted at [www.michigan.gov/cwd](http://www.michigan.gov/cwd). In addition, the U.S. Department of Agriculture may have regulations on importation from Canada. Contact them at 301-734-3277.

## Precaution about Lead in Venison

If you have questions about the health effects of lead exposure from lead shot, call the Michigan Department of Community Health at 800-648-6942 or visit [www.michigan.gov/mdch](http://www.michigan.gov/mdch).

## Dioxin Advisory Information

Health risk assessors from the DNR and the Michigan Department of Community Health determined that samples of wild game taken in 2003, 2004 and 2007 from the floodplains of the Tittabawassee River and Saginaw River downstream of Midland contain high levels of dioxin and dioxin-like compounds in muscle meats, skin and other consumable portions. Eating deer, turkey, squirrel, wood duck or Canada geese that contain dioxin at these levels could result in adverse health effects, particularly for children and women of childbearing age. Specific information can be found at [www.michigan.gov/dioxin](http://www.michigan.gov/dioxin).

## Precautions When Handling and Processing Deer and Other Game

Keep yourself and others healthy by taking care of your harvested meat. The Michigan Department of Community Health recommends proper food safety practices when cooking venison, as well as any other meat or poultry. For more information on venison field dressing, meat preparation and recipes, see the DNR publication How to Field Dress a White-Tailed Deer, available on the DNR website at [www.michigan.gov/deer](http://www.michigan.gov/deer).

## Protected Wildlife

Eagles, hawks, owls, spruce grouse, flying squirrels, wolverines, lynx, moose, cougars, cub bears and sow bears accompanied by cubs may not be taken at any time. All nongame birds are protected, except starlings, house sparrows and feral pigeons.

## Shooting Feral Swine and Ear-tagged Cervids

Hunters are encouraged to shoot feral swine year-round with any valid hunting license or a concealed pistol license. Feral swine can be taken on public land and, with permission, on private land. Hunters who shoot a feral swine are asked to submit parts of the animal to a DNR office for disease testing. If you see feral swine please record the date, time, precise location and number of swine observed and provide that information to Michelle Rosen at [rosenm@michigan.gov](mailto:rosenm@michigan.gov) or 517-336-5030 or submit it online at [www.michigan.gov/feralswine](http://www.michigan.gov/feralswine).

All exotic cervids, including all white cervids, that do not bear visible identification, found outside of a fence of a cervidae facility for more than 48 hours may be taken by hunting year-round if the individual has a valid hunting license. Report escaped cervids, call 517-373-1263

## Tagging Big Game

Immediately after killing a deer, bear, wolf, elk or turkey, you must validate your kill tag and fasten it to the antler, lower jaw or lower leg in such a manner that the tag remains securely attached to the animal. Do not stick or wrap the kill tag to the antler of a deer or to the leg of a turkey. The best way to attach a kill tag is to lay a strong piece of wire or cord across the sticky side of the kill tag so the tag can be folded in half. Tie the wire or cord to the animal. Make sure the kill tag is completely legible and visible for inspection. The kill tag must remain attached until you process or butcher the animal, or the animal is accepted for processing and recorded by a commercial processor or taxidermist.

**Note:** If the antlers or head are returned to the person submitting the animal to the commercial processor, the kill tag shall accompany the head or antlers.

## Transportation of Game

You may transport your own and another person's lawfully taken game. You cannot destroy the identity or evidence of the sex of any bird or animal, except for processed or butchered deer, bear and elk as noted below. If you are transporting migratory birds, one fully feathered wing must be left on the bird. If transporting another person's migratory birds, they must be tagged with the person's name, signature and home address, and the number of birds by species, dates of kill and small game license number.

If you butcher your deer, elk or bear, or have the animal butchered by a commercial processor before going home, the head of the animal, along with the kill tag or seal, must accompany the butchered animal during transport.

**Exception:** If you submit the head for TB or CWD testing, you must have the kill tag and disease tag receipt in your possession. Nonresidents may need to comply with restrictions in other states for importing game taken in Michigan (see Hunters Importing Deer, Elk or Moose on pg. 57).

## Important Live Animal Restrictions

**Live Animals** — it is illegal to possess live game or protected animals taken from the wild except under a permit issued by the DNR.

**Importation Bans** — it is illegal to bring live raccoon, skunk, wild rabbit or hare, feral swine, wild turkey or wild turkey hybrid or their eggs, or mute swan or their eggs into Michigan. It is illegal to import or possess a lynx or cougar without an endangered species permit. There is a moratorium on importing deer and elk into Michigan.

**Rehabilitation** — A permit is required to rehabilitate a wild animal in Michigan. It is illegal to possess a live bat, skunk, mute swan, feral swine, moose or elk. It also is illegal to rehabilitate a deer unless the origin of the deer is confirmed to be from outside Alcona, Alpena, Crawford, Montmorency, Oscoda, Otsego and Presque Isle counties. Rehabilitated raccoons must be released in the same county where captured, or they must be euthanized.

## Tracking Wounded Animals with Dogs

A licensed deer, elk or bear hunter, if accompanied by a certified dog tracker, shall not have a live round in the chamber, a cocked crossbow, or a bow with a nocked arrow, except at the time and point of kill of the wounded deer, elk or bear. For dog tracker certification requirements see WCO 2.1(a). Artificial lights ordinarily carried in the hand or on the person may be used.

## Dog Training

You may train dogs on wild animals only from Jul. 8 - Apr. 15.

**Exception:** Michigan residents may train dogs on fox on state lands in Zone 3 (see pg. 11) under special permit. For additional information on dog permits, contact Casey Reitz at 517-373-9329 or [reitzc@michigan.gov](mailto:reitzc@michigan.gov). See the 2013 Michigan Bear Hunting Digest for dog/bear training restrictions.

For information on how to release dogs from traps or snares go to [www.michigan.gov/trapping](http://www.michigan.gov/trapping) and look under Related Resources.

## Baiting and Feeding Prohibitions for Deer and Elk

**“Bait”** means a substance composed of grains, minerals, salt, fruits, vegetables, hay or other food materials, which may lure, entice or attract deer as an aid in hunting.

**Baiting is illegal** in Alpena, Alcona, Montmorency, and Oscoda counties and within the townships of Oscoda, Plainfield, Wilber, Au Sable, and Baldwin in Iosco county.

**In the rest of Michigan, the following rules apply:**

- Baiting may occur only from Oct. 1 - Jan. 1.
- Bait volume at any hunting site cannot exceed two gallons.
- Bait dispersal must be over a minimum 10-foot by 10-foot area.
- Bait must be scattered directly on the ground. It can be scattered by any means, including mechanical spin-cast feeders, provided that the spin-cast feeder does not distribute more than the maximum volume allowed.
- To minimize exposure of deer to diseases that may be present, the DNR recommends not placing bait or feed repeatedly at the same point on the ground, and only baiting when actively hunting.

**“Feed”** means a substance composed of grain, mineral, salt, fruit, vegetable, hay or other food material, that may attract deer or elk for any reason other than hunting.

**Feeding of any kind is illegal** in DMU 487.

**In the rest of Michigan, the following rules apply:**

- Feed volume at any residence cannot exceed two gallons.
- Feed may be no more than 100 yards from a residence on land owned or possessed by that person.
- Feed must be scattered on the ground. It can be scattered by any means, including mechanical spin-cast feeders, provided that the spin-cast feeder does not distribute more than the maximum volume allowed.
- Feed must be at least 100 yards from any area accessible to cattle, goats, sheep, new world camelids, bison, swine, horses or captive cervidae.

Food plots, naturally occurring foods, standing agricultural crops or food placed as a result of using normal agricultural practices are not considered to be bait or feed. Food plots may not be planted on public land.

## Additional Hunting Rules

**It is illegal to:**

- Assist a tribal member engaged in treaty-authorized hunting unless the non-tribal member assisting: 1) has a state license for that activity and complies with all state laws, including season dates covering that activity, or 2) is the spouse, parent, grandparent, child, grandchild or sibling of the tribal member who is present during the activity, and as long as such assistance by the family member does not include using a firearm, crossbow or bow.

- Hunt or pursue wild animals or birds from a car, snowmobile, aircraft, motorboat, personal water craft, ORV or other motorized vehicle, or by a sailboat.  
**Exceptions:** See 2013-2014 Michigan Waterfowl Hunting Digest; special permits may also apply.
- Set fires to drive out game. Use snares, traps, cages, nets, pitfalls, deadfalls, spears, drugs, poisons, chemicals, smoke, gas, explosives, ferrets, weasels or mechanical devices other than firearms, crossbows, bows and arrows, or slingshots to take wild birds or animals, except as provided by trapping rules or special permit.
- Buy or sell game, except as provided by the Wildlife Conservation Order 4.3.
- Destroy the identity of game or evidence of the sex of game while in the field or when transported in a motor vehicle. **Exception:** See Transportation of Game, pg. 58, for deer, bear and elk.
- Hunt from a tree, raised platform or scaffold with a firearm. **Exceptions:** See pg. 22 for rules when hunting bear, deer, wolf, fox and coyote. Also see 2013-2014 Michigan Waterfowl Hunting Digest for waterfowl hunting blind regulations.
- Hunt while under the influence of intoxicating alcohol or controlled substances.
- Use cartridges containing tracer or explosive bullets. A silencer or similar apparatus on a firearm is illegal.
- Camp on state land without a permit. Permits are free and are available online at [www.michigan.gov/stateforestcampgrounds](http://www.michigan.gov/stateforestcampgrounds) or at any DNR office. They must be posted at your campsite. A fee is charged for camping at designated campsites in state parks, recreation areas, state forest campgrounds and some state game areas.
- Make use of a dog in hunting deer, elk, or wolf, except that a dog may be used to locate a down or mortally wounded deer or elk if the dog is kept on a leash and those in attendance do not possess a firearm, crossbow or bow. Exception: If accompanied by a licensed dog tracker, a hunter may possess a firearm, a cocked crossbow, or a bow with nocked arrow, only at the time and point of kill. If the tracking is done at night, artificial lights ordinarily carried in the hand, or on the person, may be used. A dog that barks while tracking the deer shall not be used on public lands.
- Harm or harass a deer or bear when it is swimming in a stream, river, pond, lake or other water body.
- Kill or wound any game without making a reasonable attempt to retrieve the animal and include it in the daily bag.
- Shoot reptiles and amphibians with a firearm (including spring, air or gas propelled).

### Commercial Hunting Guides on Public Land

All commercial hunting guides utilizing state-owned lands must receive written authorization. Guides are also required to meet the conditions of the written authorization. If you are a guide who utilizes state-owned lands, please visit the DNR website at [www.michigan.gov/wildlifepermits](http://www.michigan.gov/wildlifepermits) or contact Casey Reitz at reitzc@michigan.gov or (517) 373-9329 for more information.

Commercial guiding on National Forest (NF) lands requires a federal special use permit. Applications can be obtained through any NF office or by calling - Hiawatha NF: 906-428-5800; Huron-Manistee NF: 231-775-5023; or Ottawa NF: 906-932-1330.

### Hunting on National Forest Lands ([www.fs.fed.us](http://www.fs.fed.us))

All state laws apply to National Forest lands; however, additional federal regulations also apply.

**Wheeled Motor Vehicle Use:** A motor vehicle use map that shows designated roads and trails open for motorized travel, including off-road vehicles, is available at Forest Service offices as well as online.

- Leaving equipment unattended for more than 24 hours is prohibited.
- Cross-country travel off designated routes is prohibited.
- Driving a motorized vehicle cross-country to blinds or to retrieve game is illegal except if it is a personal assisted mobility device.

**Camping:** Camping in developed recreation areas is limited to 14 consecutive days, and camping in dispersed areas is limited to 16 consecutive days.

- Leaving camping equipment unattended for more than 24 hours in a developed recreation area is prohibited.
- Campfires must be attended at all times and extinguished completely when you leave.
- Campers/trailers on National Forest land must be properly licensed or registered.

**Blinds:** Failure to remove ANY type of blind, structure, equipment or trash will result in a fine and removal, destruction, impoundment and/or seizure of any abandoned or illegally placed items.

- Cutting of branches or limbs for shooting lanes or to construct blinds is prohibited.

**Additional Information:**

- Constructing or maintaining any food plot or any artificial garden to attract wildlife is prohibited.
- Blocking gates or road access or dragging forest road is prohibited.
- Discharging a weapon within 150 yards of a building, campsite or occupied area or across or on a National Forest road or body of water is prohibited.
- Guiding on National Forest land requires a federal special use permit.

Contact information: Hiawatha NF: 906-428-5800;  
Huron-Manistee NF: 231-775-5023; Ottawa NF: 906-932-1330.



## Show Your Support for Michigan's Nongame Wildlife

Purchasing nongame wildlife items puts your dollars directly into the Nongame Wildlife Fund. To see all available patches and make a purchase or donation online, visit: [www.michigan.gov/estore](http://www.michigan.gov/estore).

SEND ORDER TO: Please print clearly or affix an address label. Allow 4 to 6 weeks for delivery.	
ADDRESS:	
CITY, STATE, ZIP:	
TELEPHONE: (with area code)	
	<b>QTY</b>
<b>2012/2013 and 2013/2014 patches are \$10 each</b>	
Passenger Pigeon 2013/2014	
Massasauga Rattlesnake 2012/2013	
<b>All 2011/2012 and older patches are \$6 each.</b>	
To see all available patches for sale, visit: <a href="http://www.michigan.gov/estore">www.michigan.gov/estore</a>	
Prairie Vole 2011/2012	
Eastern Box Turtle 2010/2011	
Monarch Butterfly 2009/2010	
Copperbelly Snake 2008/2009	
<b>Subtotal \$</b>	
Please mail completed form with check payable to "State of Michigan" to: Michigan DNR P.O. Box 30451 Lansing, MI 48909-7951	
<b>Subtotal</b>	<b>FOR DNR CASHIER'S USE ONLY - DO NOT USE SPACE BELOW</b>
Michigan Sales Tax (Multiply by .06)	
Shipping and Handling \$0-\$20, add \$2.50, \$20.01 and up, add \$5	
<b>Grand Total</b>	



# 5 REASONS TO JOIN QDMA



QDMA members made it possible for this young hunter to take her first deer at QDMA's 2012 National Youth Hunt.

<http://www.qdma.com/directory/Michigan>

JOIN TODAY!

NEW MI MEMBERS RECEIVE  
**\$5 OFF**  
A \$30 MEMBERSHIP  
USE CODE: MHG13



**RESEARCH**  
support deer research

**EDUCATE**  
receive the latest cutting-edge information

**ADVOCATE**  
speak for wise whitetail management

**CERTIFY**  
support programs for deer hunters in your area

**HUNT!**  
ensure your hunting legacy for the future

WHAT A DIFFERENCE A YEAR MAKES!



Your membership dollars fund every arm of QDMA's mission... providing benefits to you, the whitetail resource, and tomorrow's hunters.

HELP ENSURE THE FUTURE OF WHITE-TAILED DEER, WILDLIFE HABITAT AND OUR HUNTING HERITAGE.



(800) 209-3337 • QDMA.COM

Follow Us on Facebook  
**MiQDMA**

Your Waterfowling Experts  
**Fowl Foolers**  
AMERICAN MADE

"The Original"  
Burlap-Wrapped Decoys  
Snow & Ice Resistant Decoys  
Fowl Foolers™ Flapper Calls  
Clothing

2435 East Gill Road, Port Clinton, Ohio 43452  
TEL (419) 960-7307 • FAX (419) 734-9275  
info@fowlfoolers.com  
[www.fowlfoolers.com](http://www.fowlfoolers.com)

**Q1 BUCKPOLE**

Free Entry!  
Register Your Buck and Doe!

**ENTER TO WIN A BRAND NEW ATV!**  
ATV TO BE GIVEN AWAY IN A RANDOM DRAW OF ALL ENTRIES

Watch us on TV and Online  
Weekly feature in 2013:  
The DNR talks about hot topics for Michigan hunters!

[WWW.Q1BUCKPOLE.COM](http://WWW.Q1BUCKPOLE.COM)  
Find your nearest registration location by going online.

Presented by  
**Soaring Eagle**  
Casino & Resort

**GreenStone**  
FARM CREDIT SERVICES  
tonysuim.com

Q1 Broadcasting : 517.279.8752 Tim Hart: timbahart@gmail.com

**GET OUT THERE and BACK with DISCOUNT TIRE**

**TIRES & WHEELS FOR ALL YOUR OUTDOOR NEEDS!**

**GO TO DISCOUNTTIRE.COM TO FIND A LOCATION NEAR YOU!**  
56 STORES IN MICHIGAN AND OVER 850 NATIONWIDE!

EVERY SEASON STARTS AT



FIELD & STREAM. 1871



Remington.



TAKE \$10 OFF

YOUR NEXT HUNTING PURCHASE OF \$50 OR MORE

Limit one coupon per customer. Minimum purchase of \$50 before sales tax. Total amount of coupon must be redeemed at one time. Cannot be combined with any other offers, coupons, team discounts or Guaranteed In-Stock markdown, or used for licenses or previously purchased merchandise. Coupon valid on in-store purchases only. Not redeemable for cash, gift cards or store credit. No reproductions or rain checks accepted. Returns or exchanges where a ScoreCard Reward or other discount was applied may result in an adjusted refund amount. Excludes firearms, ammunition and Under Armour. Some additional exclusions may apply. See store for details.

Valid 6/26/13 through 6/26/14.



P00014019

EVERY HUNT STARTS AT DICK'S

TO FIND A STORE NEAR YOU 1.866.819.0038 DICKSSPORTINGGOODS.COM

Dunham's WAYS TO SAVE Dunham's

REWARDS REWARDS

EMAIL

Visit <http://www.dunhamsrewards.com/huntingmi> Receive great coupons for the sports you love!

MOBILE TEXT ALERTS

Visit <http://www.dunhamssports.com/mobile> Receive exclusive coupons and offers!



For All Your Hunting Needs

Dunham's SPORTS

Clip And Save Clip And Save Clip And Save

20% OFF\* Regular Price Of Any One Item In Stock With Coupon

\*Excludes: firearms, ammunition, licenses, Ugg, Merrell Footwear, select Nike and TaylorMade product, Under Armour, all Titleist golf balls, any regular priced bat \$199.99 and up, KL Pro 120 boat/trailer, augers, shanties, GPS/fish finders, trolling and outboard motors, marine batteries, motorized vehicles, Columbia Omni Heat, gift cards, special order items. Cannot be used with any other offer, coupon, current sale or clearance item. Only one coupon applied per item. One coupon per customer. Not valid on previous purchases. Void if copied. Not for resale.



Coupon Expires July 31, 2014



07558000000000

## Need information?

Contact a Customer Service Center listed below. Centers are open Monday through Friday, 8 a.m. to 5 p.m. or visit us online.

### Baraga

427 US-41 North  
Baraga, MI 49908  
906-353-6651

### Bay City

3580 State Park Drive  
Bay City, MI 48706  
989-684-9141

### Cadillac

8015 Mackinaw Trail  
Cadillac, MI 49601  
231-775-9727

### Gaylord

1732 W. M-32  
Gaylord, MI 49735  
989-732-3541

### Marquette

1990 US-41 South  
Marquette, MI 49855  
906-228-6561

### Newberry

5100 M-123  
Newberry, MI 49868  
906-293-5131

### Plainwell

621 N. 10th St.  
Plainwell, MI 49080  
269-685-6851

### Roscommon

I-75 & M-18 South,  
8717 N. Roscommon Rd.  
Roscommon, MI 48653  
989-275-5151

### Rose Lake\*

8562 E. Stoll Rd.  
East Lansing, MI 48823  
517-641-4903

(\*This is a field office)

### Southfield

26000 W. Eight Mile Rd.  
Southfield, MI 48034  
248-359-9040

### Helpful URLs:

Learn more about the DNR: [www.michigan.gov/dnr](http://www.michigan.gov/dnr)

Find us on Facebook at [www.facebook.com/midnr](http://www.facebook.com/midnr)

Follow us on Twitter at [www.twitter.com/MichiganDNR](http://www.twitter.com/MichiganDNR)



### Sign up for e-mail from the DNR!

Visit [www.michigan.gov/dnr](http://www.michigan.gov/dnr) and click on the red envelope.

### Direct DNR website URLs:

Hunting and Trapping: [www.michigan.gov/hunting](http://www.michigan.gov/hunting)

Pure Michigan Hunt: [www.michigan.gov/puremichiganhunt](http://www.michigan.gov/puremichiganhunt)

DNR Digests and Guides: [www.michigan.gov/dnrdigests](http://www.michigan.gov/dnrdigests)

Michigan Waterfowl Legacy: [www.michigan.gov/mwl](http://www.michigan.gov/mwl)

Deer: [www.michigan.gov/deer](http://www.michigan.gov/deer)

Black Bear: [www.michigan.gov/bear](http://www.michigan.gov/bear)

Wild Turkeys: [www.michigan.gov/turkey](http://www.michigan.gov/turkey)

Wolf: [www.michigan.gov/wolves](http://www.michigan.gov/wolves)

Elk: [www.michigan.gov/elk](http://www.michigan.gov/elk)

Ducks and Geese: [www.michigan.gov/waterfowl](http://www.michigan.gov/waterfowl)

Information and "How To" of Trapping and Fur Harvesting: [www.michigan.gov/trapping](http://www.michigan.gov/trapping)

Mi-HUNT: [www.michigan.gov/mihunt](http://www.michigan.gov/mihunt)

Explore Michigan's Wetland Wonders: [www.michigan.gov/wetlandwonders](http://www.michigan.gov/wetlandwonders)

Public Hunting on Private Lands: [www.michigan.gov/hap](http://www.michigan.gov/hap)

Invasive Species: [www.michigan.gov/invasivespecies](http://www.michigan.gov/invasivespecies)

Shooting Ranges: [www.michigan.gov/shootingranges](http://www.michigan.gov/shootingranges)

Emerging Diseases: [www.michigan.gov/wildlifedisease](http://www.michigan.gov/wildlifedisease)

### Michigan Department of Natural Resources

#### Wildlife Division

530 W. Allegan Street

PO Box 30444

Lansing, MI 48933

(517) 373-1263